

POLY FLEX DATA SHEET

PRODUCT: MOUNT **P-SYSTEM**®

MODEL: **P#6.8F80-12-20 Gen**

IDENTIFICATION SYSTEM				
P# 6 . 8 F 80 - 12 - 20 Gen				
BASE TYPE	CORE DIA.	CORE HEIGHT	THREAD SIZE	CORE HARDNESS

CORE COLOUR	SHORE HARDNESS
ORANGE	50
BLUE	60
YELLOW	70
LIGHT GREEN	80

MATERIAL SPECIFICATION	
* ENGINEERING GRADE HEAT CURED POLYMER ALLOY	
* ALL METAL PARTS - GOLD PASSIVATED ZINC PLATED	

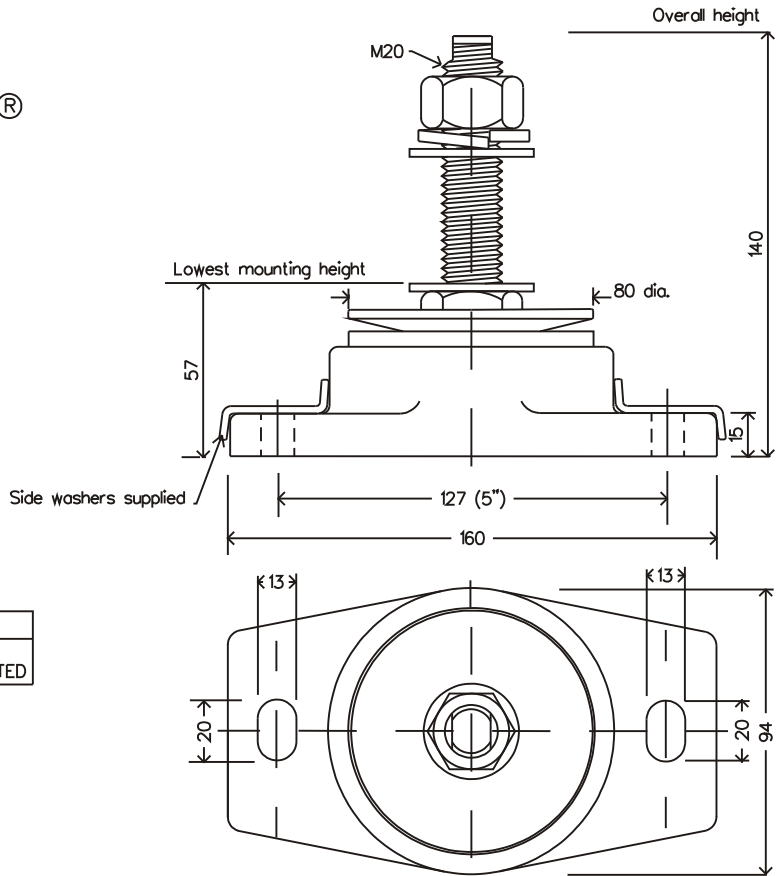

Dimensions are in mm.

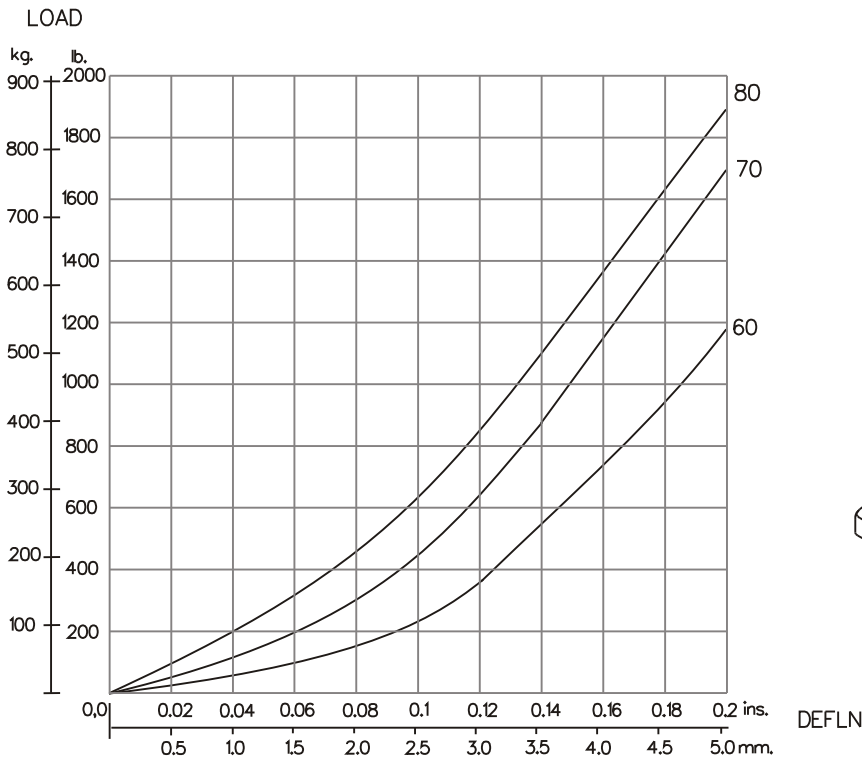

GRAPH 1 : STATIC AXIAL (VERTICAL) LOAD VS. DEFLECTION

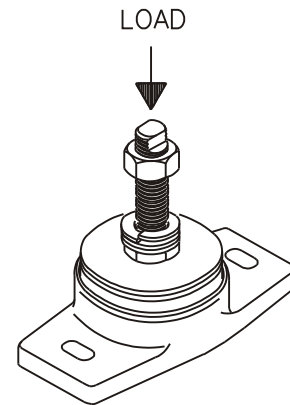

THE ABOVE DATA IS SUPPLIED AS A GUIDE ONLY
PRODUCT SPECIFICATIONS AND DATA SHEETS ARE SUBJECT TO CHANGE WITHOUT NOTICE.

Poly Flex © 1999
Products

DRAWING NO: D6-8F20G
DRAWN PB. 10/11/99