

POLY FLEX DATA SHEET

PRODUCT: MOUNT **P-SYSTEM**®

MODEL: **P#6.5F73-11-16**

GEN-SET & MACHINERY MOUNT

| IDENTIFICATION SYSTEM | | | | |
|--|-----------|-------------|-------------|---------------|
| P# <u>XX</u> F <u>XX</u> - <u>XX</u> - <u>XX</u> (<u>XX</u>) | | | | |
| BASE TYPE | CORE DIA. | CORE HEIGHT | THREAD SIZE | CORE HARDNESS |

| CORE COLOUR | SHORE HARDNESS |
|-------------|----------------|
| ORANGE | 50 |
| BLUE | 60 |
| YELLOW | 70 |

| MATERIAL SPECIFICATION |
|---|
| * ENGINEERING GRADE HEAT CURED POLYMER ALLOY |
| * ALL METAL PARTS - GOLD PASSIVATED ZINC PLATED |

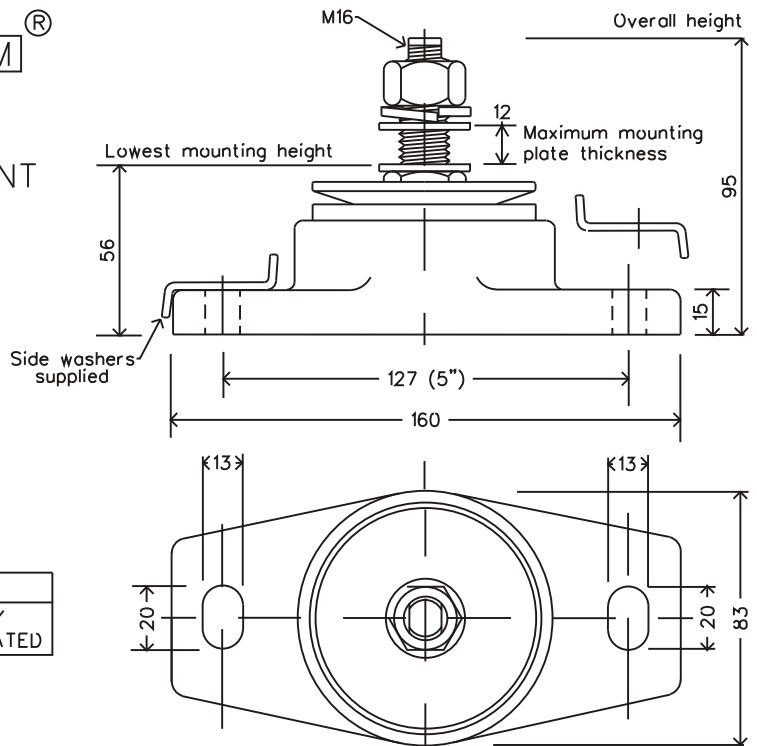

Dimensions are in mm.

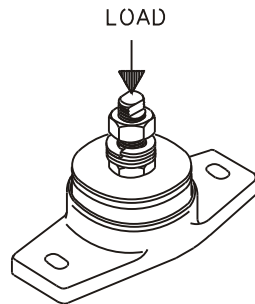
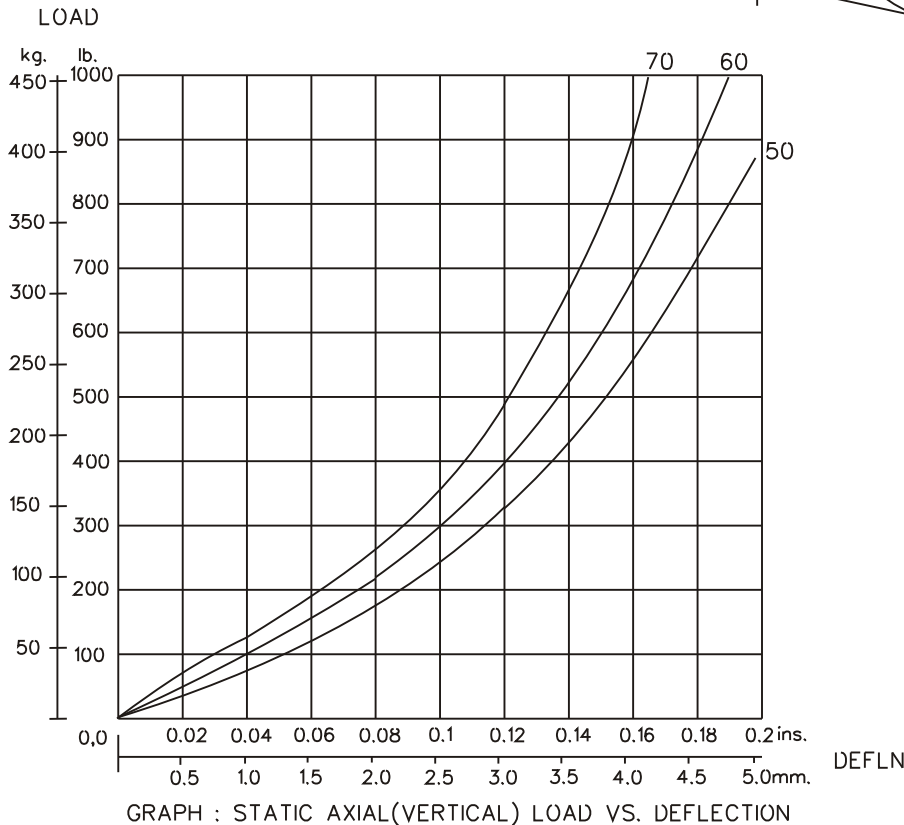

SUGGESTED CORE HARDNESS FOR: LIGHT DUTY
HEAVY DUTY

THE ABOVE DATA IS SUPPLIED AS A GUIDE ONLY
PRODUCT SPECIFICATIONS AND DATA SHEETS ARE SUBJECT TO CHANGE WITHOUT NOTICE.

Poly Flex © 1996
Products

DRAWING NO: P6-5FG16
DRAWN PB. 22/1/96