

POLY FLEX DATA SHEET

PRODUCT: MOUNT **P-SYSTEM**®  
MODEL: **P#3.5CTF60-15-12GEN**

IDENTIFICATION SYSTEM				
P#FXX-XX-XX (XX)				
BASE TYPE	CORE DIA.	CORE HEIGHT	THREAD SIZE	CORE HARDNESS

CORE COLOUR	SHORE HARDNESS
ORANGE	50
BLUE	60
YELLOW	70

MATERIAL SPECIFICATION
* ENGINEERING GRADE HEAT CURED POLYMER ALLOY
* ALL METAL PARTS - GOLD PASSIVATED ZINC PLATED

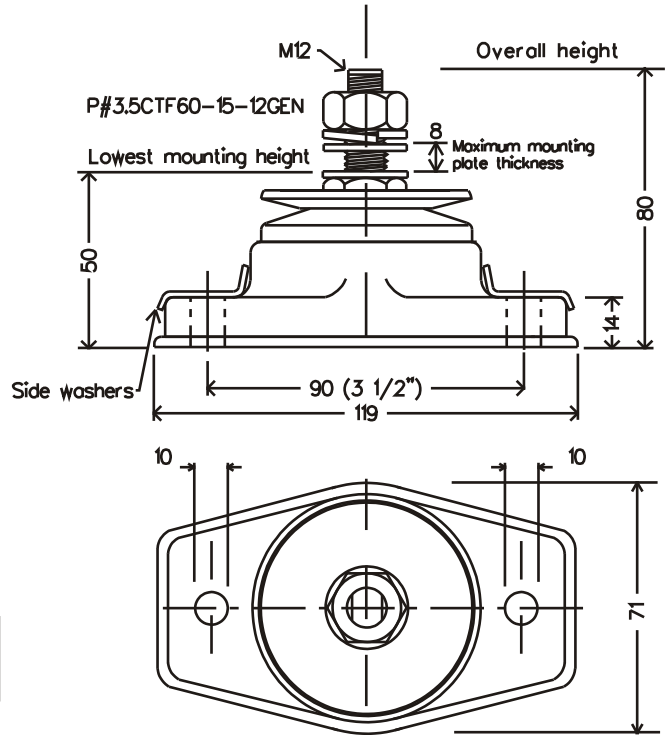

Dimensions are in mm.

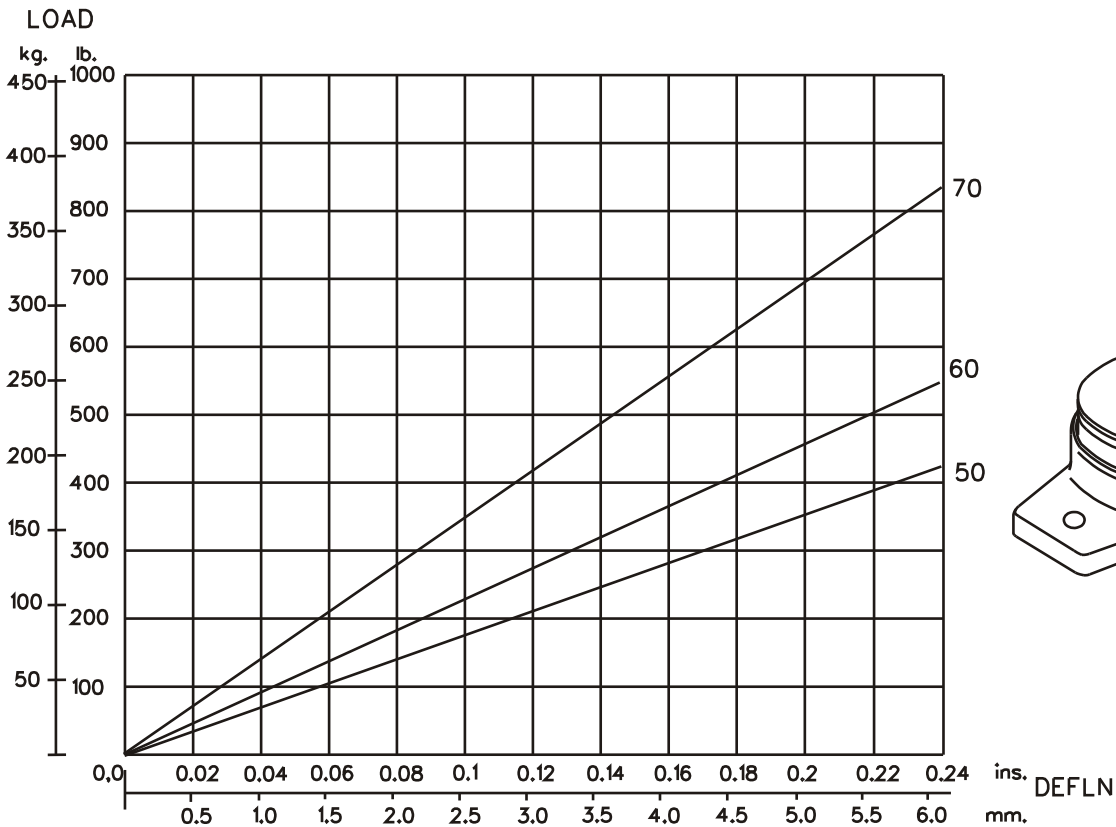

GRAPH 1 : STATIC AXIAL(VERTICAL) LOAD VS. DEFLECTION

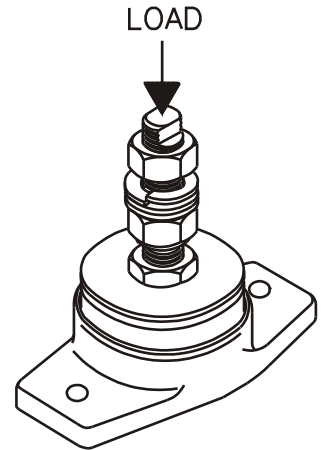

**Poly Flex** © 2002  
Products

DRAWING NO: D3-5C12G  
DRAWN PB. 27/6/02