

**POLY FLEX DATA SHEET**

PRODUCT: MOUNT **P-SYSTEM**®

MODEL: **P#2.5F50-11-12**

GEN-SET & MACHINERY MOUNT

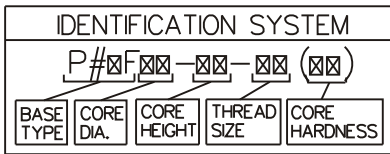

CORE COLOUR	SHORE HARDNESS
ORANGE	50
BLUE	60
YELLOW	70

**MATERIAL SPECIFICATION**

- \* ENGINEERING GRADE HEAT CURED POLYMER ALLOY
- \* ALL METAL PARTS - GOLD PASSIVATED ZINC PLATED

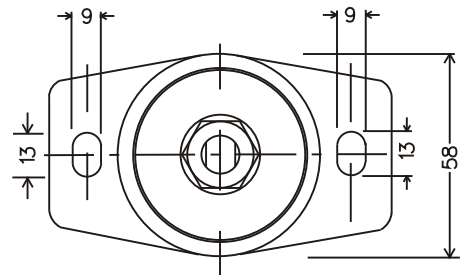
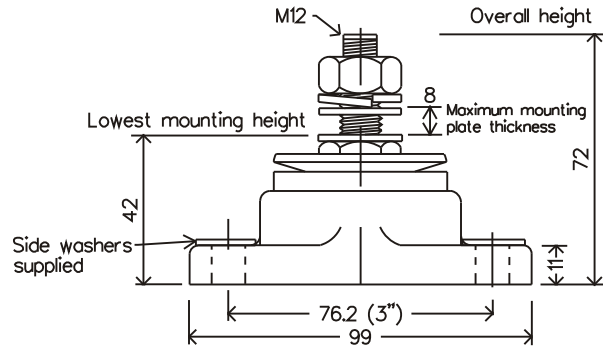

Dimensions are in mm.

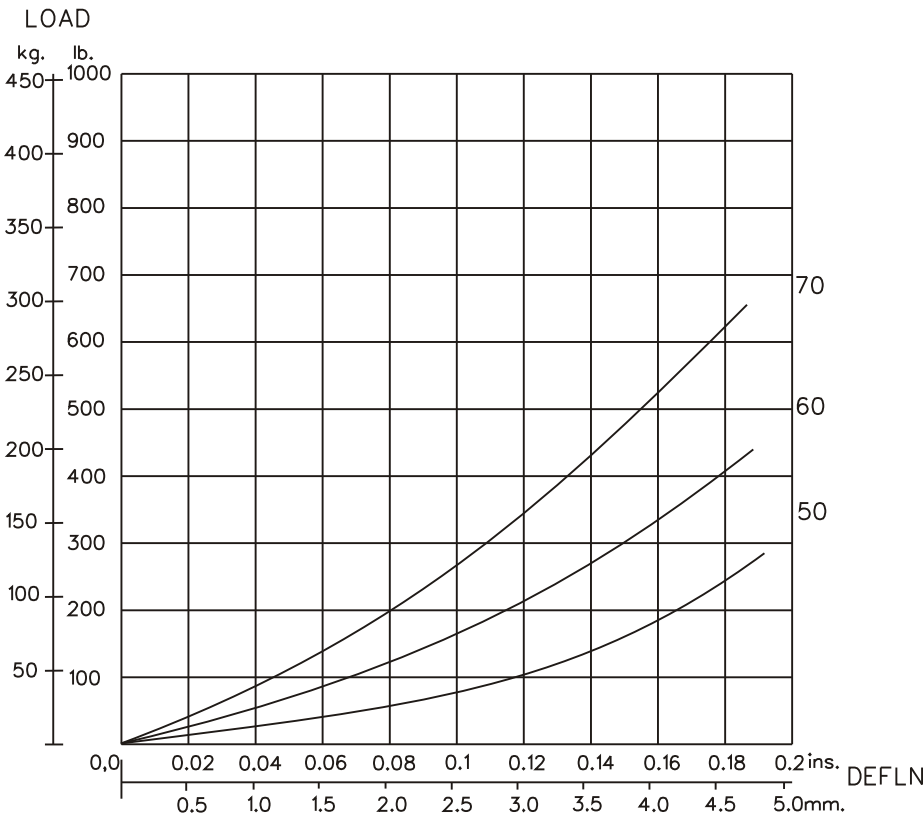

GRAPH 1 : STATIC AXIAL(VERTICAL) LOAD VS. DEFLECTION

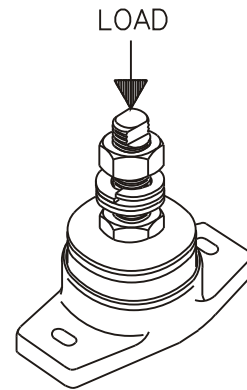

SUGGESTED CORE HARDNESS FOR: LIGHT DUTY   
HEAVY DUTY

THE ABOVE DATA IS SUPPLIED AS A GUIDE ONLY  
PRODUCT SPECIFICATIONS AND DATA SHEETS ARE SUBJECT TO CHANGE WITHOUT NOTICE.

**Poly Flex** © 1996  
Products

DRAWING NO: 2-550G12  
DRAWN PB. 6/5/96