

POLY FLEX DATA SHEET

PRODUCT: MOUNT **P-SYSTEM**®

MODEL: **P#7.8F80-12-20**

IDENTIFICATION SYSTEM				
P#FXX-XX-XX (XX)				
BASE TYPE	CORE DIA.	CORE HEIGHT	THREAD SIZE	CORE HARDNESS

CORE COLOUR	SHORE HARDNESS
ORANGE	50
BLUE	60
YELLOW	70
LIGHT GREEN	80

MATERIAL SPECIFICATION
* ENGINEERING GRADE HEAT CURED POLYMER ALLOY
* ALL METAL PARTS - GOLD PASSIVATED ZINC PLATED

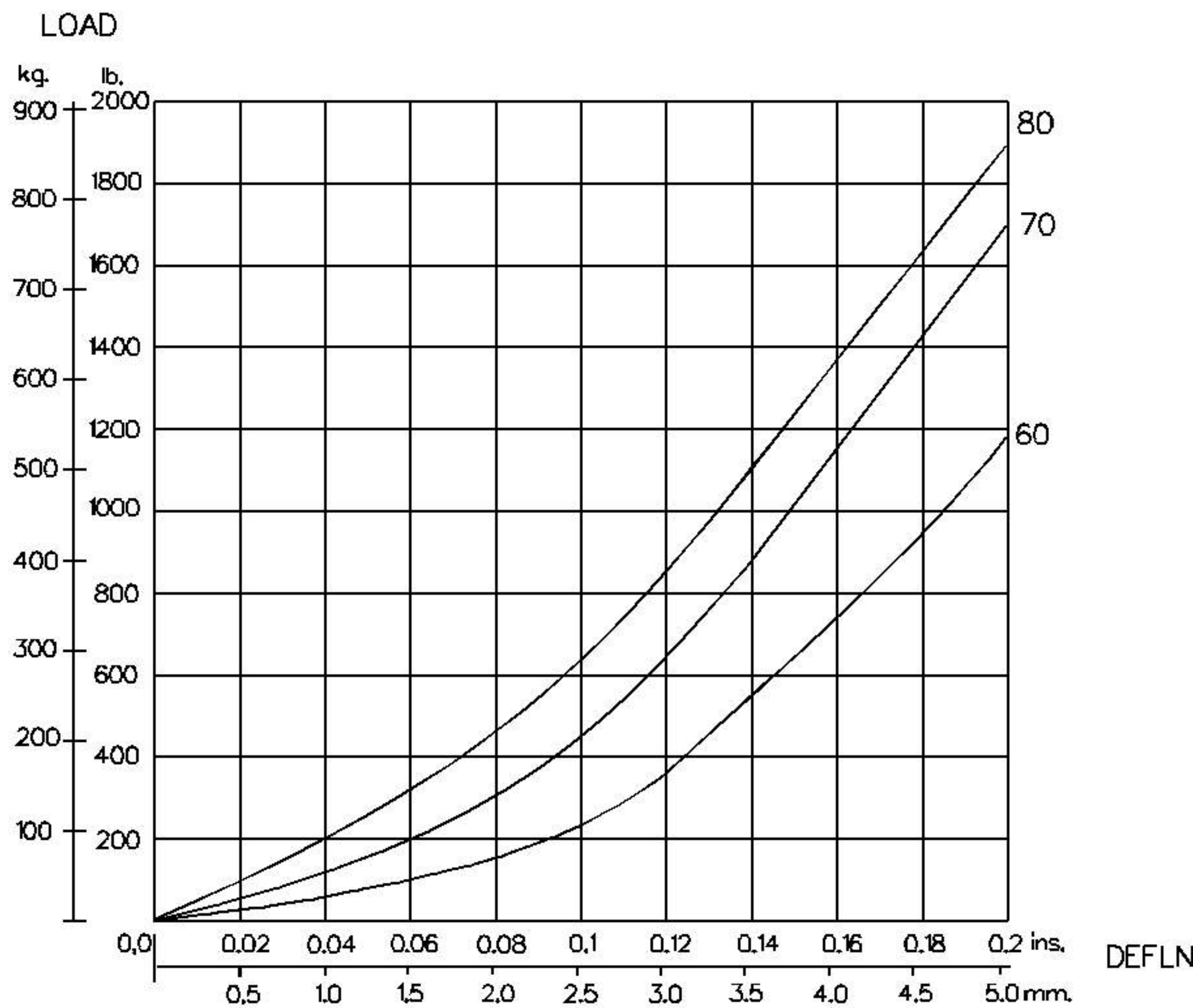
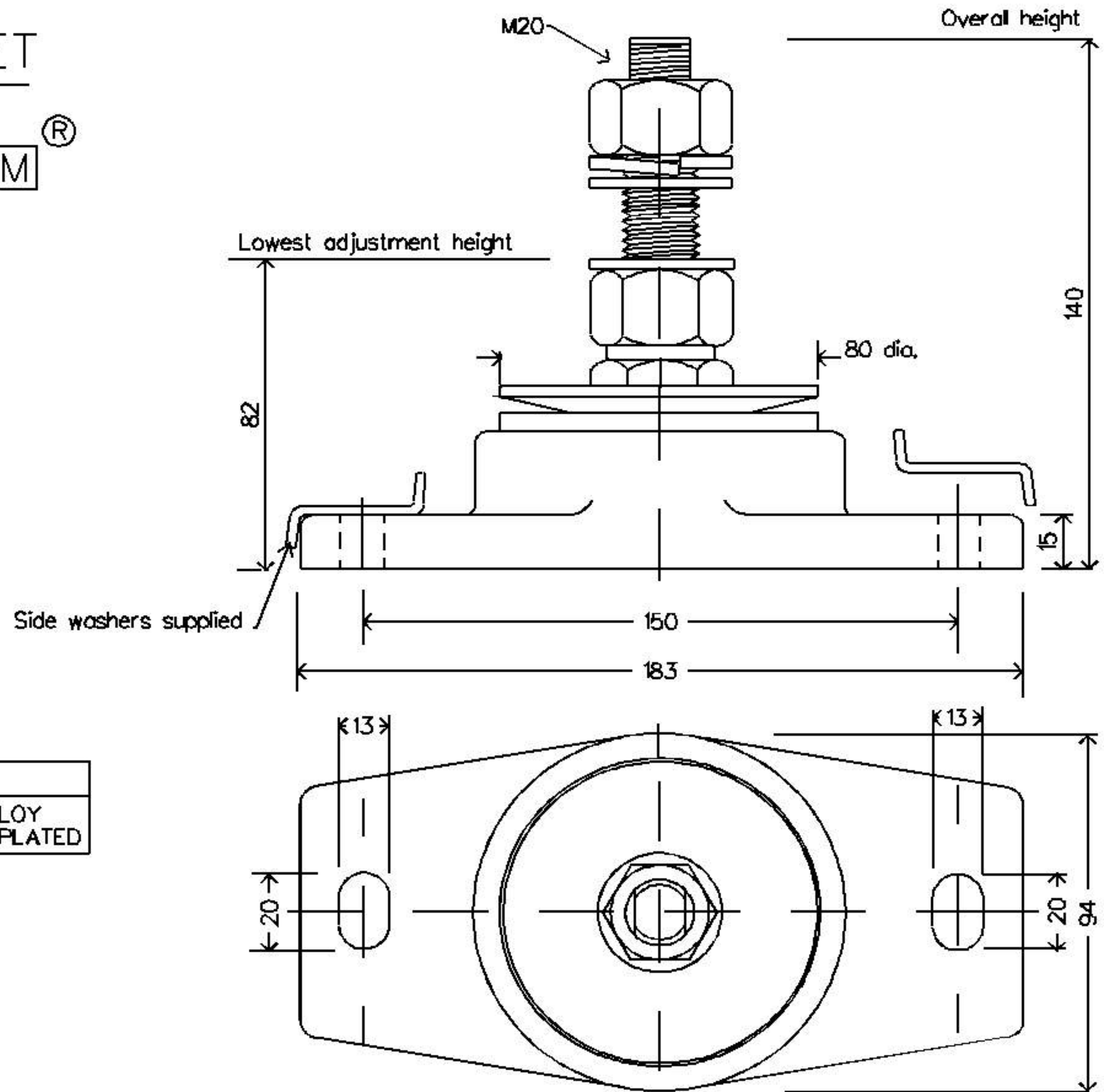

GRAPH 1 : STATIC AXIAL(VERTICAL) LOAD VS. DEFLECTION

SUGGESTED CORE HARDNESS FOR: LIGHT DUTY
HEAVY DUTY

THE ABOVE DATA IS SUPPLIED AS A GUIDE ONLY
PRODUCT SPECIFICATIONS AND DATA SHEETS ARE SUBJECT TO CHANGE WITHOUT NOTICE.

Dimensions are in mm.

