

POLY FLEX DATA SHEET

PRODUCT: MOUNT **P-SYSTEM**®

MODEL: **P#6.8F80-12-20**

IDENTIFICATION SYSTEM				
P# 6 F 80 - 12 - 20				
BASE TYPE	CORE DIA.	CORE HEIGHT	THREAD SIZE	CORE HARDNESS

CORE COLOUR	SHORE HARDNESS
BLUE	60
YELLOW	70
LIGHT GREEN	80

MATERIAL SPECIFICATION	
* ENGINEERING GRADE HEAT CURED POLYMER ALLOY	
* ALL METAL PARTS - GOLD PASSIVATED ZINC PLATED	

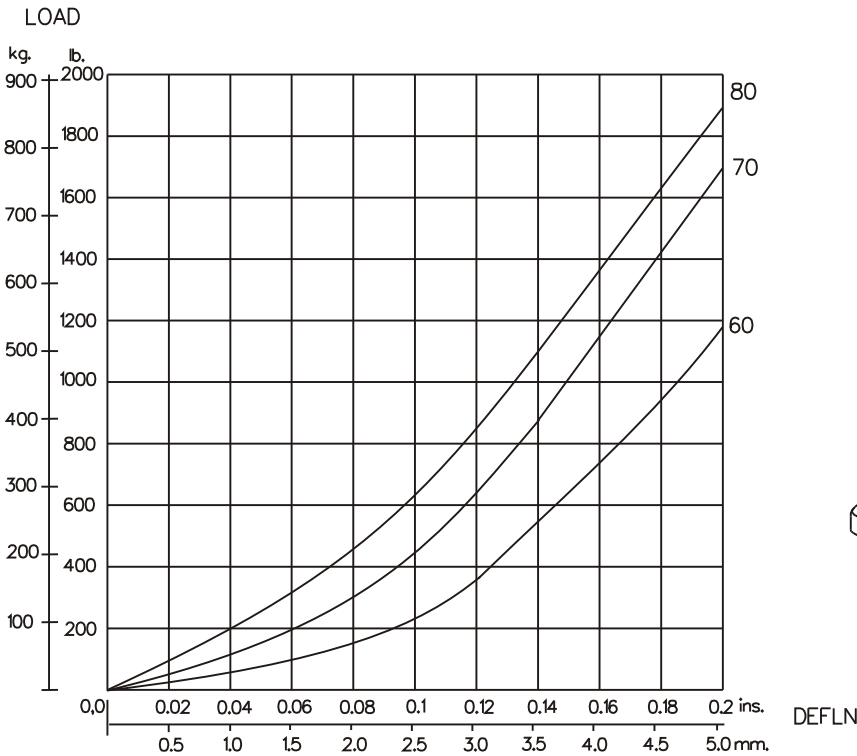
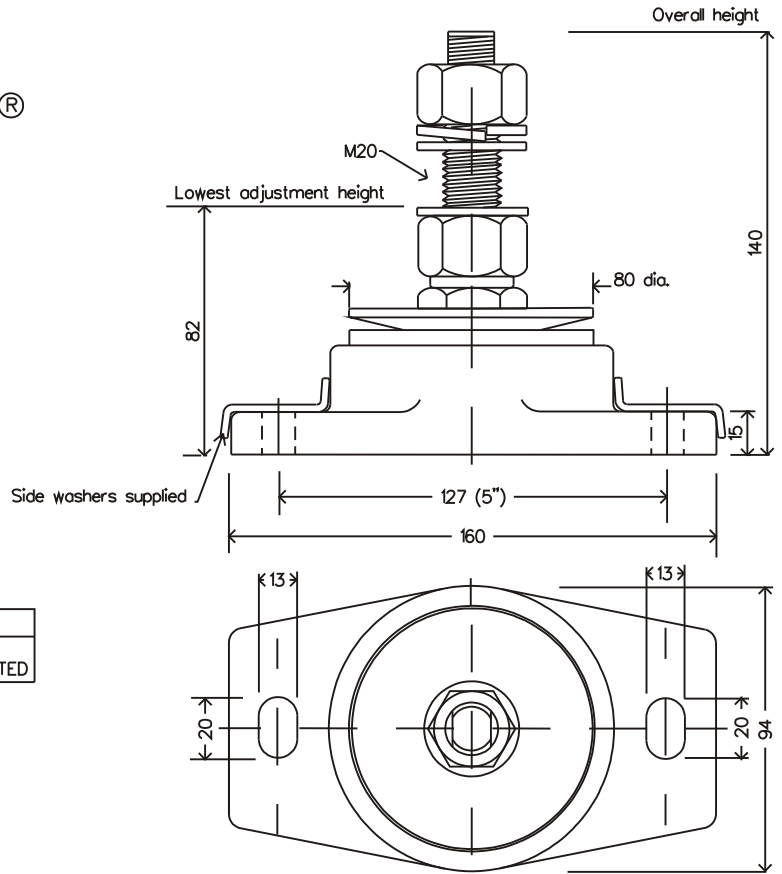

GRAPH 1 : STATIC AXIAL(VERTICAL) LOAD VS. DEFLECTION

SUGGESTED CORE HARDNESS FOR: LIGHT DUTY
HEAVY DUTY

THE ABOVE DATA IS SUPPLIED AS A GUIDE ONLY
PRODUCT SPECIFICATIONS AND DATA SHEETS ARE SUBJECT TO CHANGE WITHOUT NOTICE.

Dimensions are in mm.

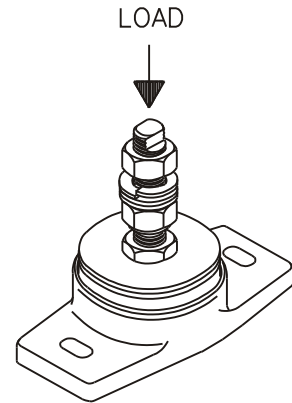

Poly Flex © 1998
Products

DRAWING NO: D6-8F20
DRAWN PB. 27/1/98