

POLY FLEX DATA SHEET

PRODUCT: MOUNT **P-SYSTEM**[®]
MODEL: **P#6.8F80-12-16**

IDENTIFICATION SYSTEM				
P#FXX-XX-XX(XX)				
BASE TYPE	CORE DIA.	CORE HEIGHT	THREAD SIZE	CORE HARDNESS

CORE COLOUR	SHORE HARDNESS
BLUE	60
YELLOW	70
LIGHT GREEN	80

MATERIAL SPECIFICATION	
* ENGINEERING GRADE HEAT CURED POLYMER ALLOY	
* ALL METAL PARTS - GOLD PASSIVATED ZINC PLATED	

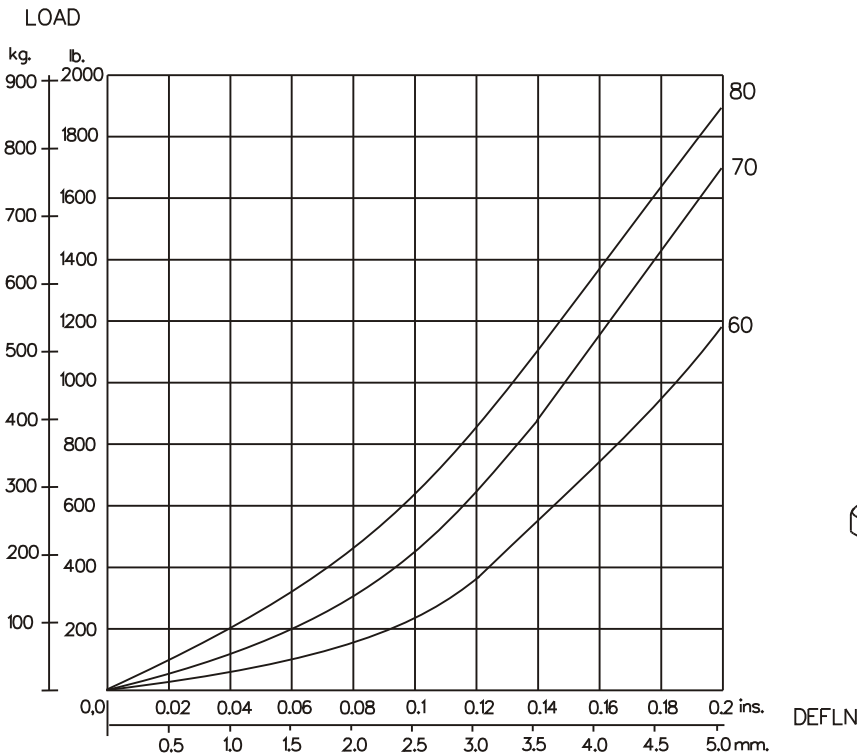
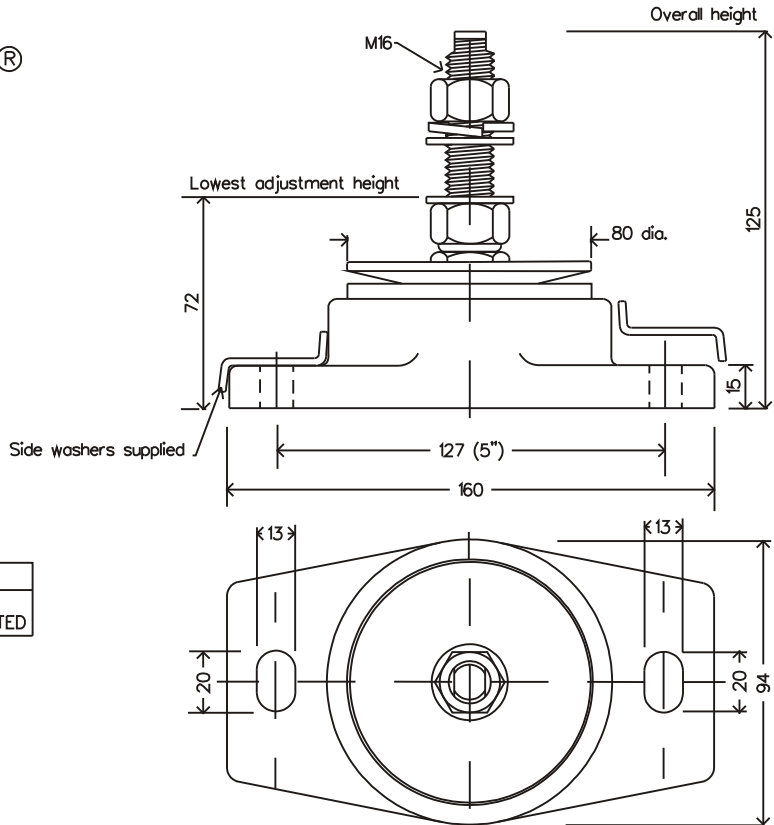

GRAPH 1: STATIC AXIAL(VERTICAL) LOAD VS. DEFLECTION

SUGGESTED CORE HARDNESS FOR: LIGHT DUTY
HEAVY DUTY

THE ABOVE DATA IS SUPPLIED AS A GUIDE ONLY. PRODUCT SPECIFICATIONS AND DATA SHEETS ARE SUBJECT TO CHANGE WITHOUT NOTICE.

Dimensions are in mm.

