

POLY FLEX DATA SHEET

PRODUCT: MOUNT **P-SYSTEM**®

MODEL: **P#5.5CTF65-20-20**

IDENTIFICATION SYSTEM				
P# <u>5</u> F <u>5</u> - <u>20</u> - <u>20</u> ( <u>55</u> )				
BASE TYPE	CORE DIA.	CORE HEIGHT	THREAD SIZE	CORE HARDNESS

CORE COLOUR	SHORE HARDNESS
ORANGE	50
BLUE	60
YELLOW	70

MATERIAL SPECIFICATION	
* ENGINEERING GRADE HEAT CURED POLYMER ALLOY	
* ALL METAL PARTS - GOLD PASSIVATED ZINC PLATED	

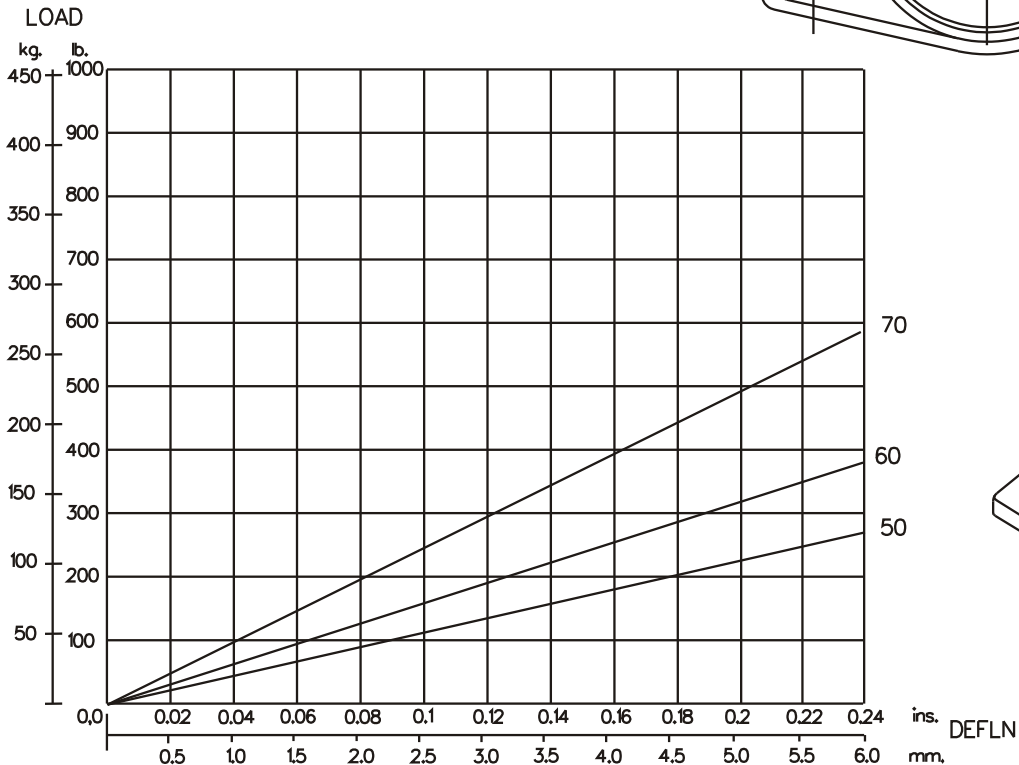
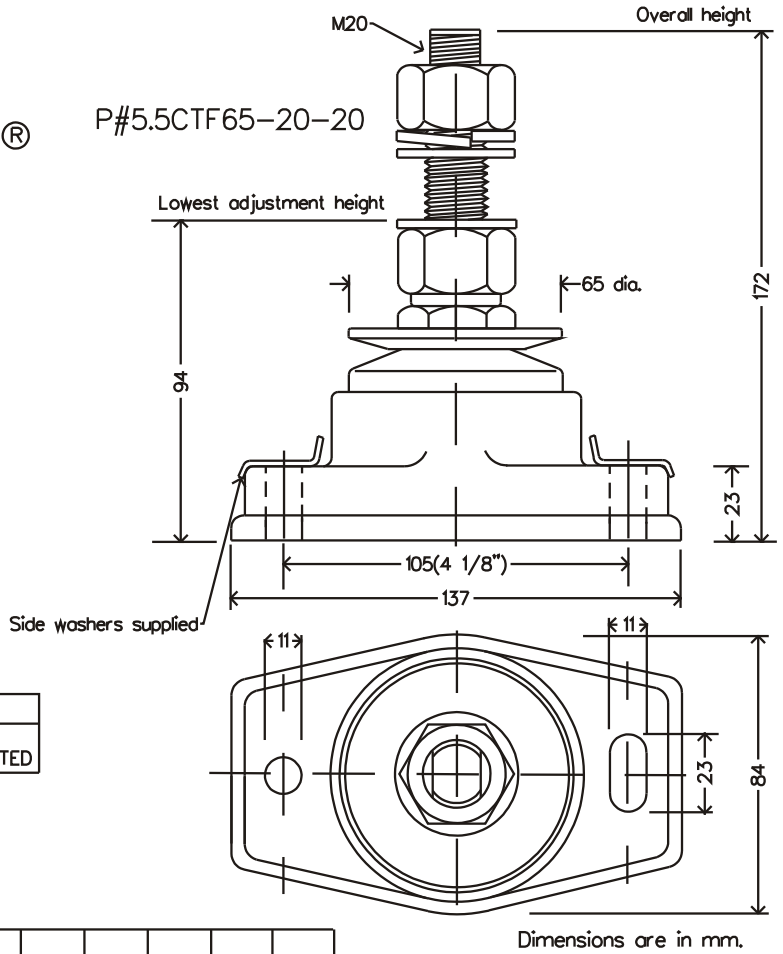

GRAPH 1: STATIC AXIAL (VERTICAL) LOAD VS. DEFLECTION

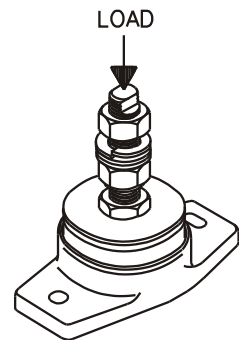

**Poly Flex** © 2001  
Products  
DRAWING NO: D5-5CT20  
DRAWN PB. 3/12/01