

**POLY FLEX DATA SHEET**

PRODUCT: MOUNT P-SYSTEM®

SERIES: P FLUSH SERIES®

MODEL: P#4F 64-17-12 ( ) SEAWASP BUILD

MATERIAL SPECIFICATION	
• ENGINEERING GRADE HEAT CURED POLYMER ALLOY	
• ALL METAL PARTS – SA5 COBALT ZINC PLATED	

CORE COLOUR	SHORE HARDNESS
ORANGE	50
BLUE	60
YELLOW	70

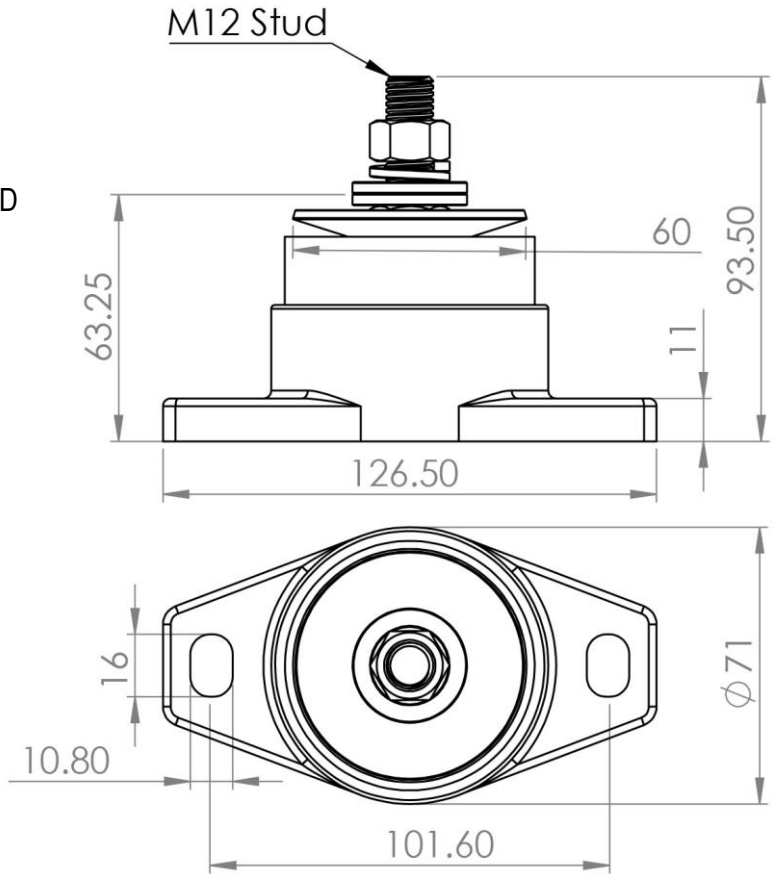

THE FOLLOWING DATA IS SUPPLIED AS A GUIDE ONLY. PRODUCT SPECIFICATIONS AND DATA SHEETS ARE SUBJECT TO CHANGE WITHOUT NOTICE.

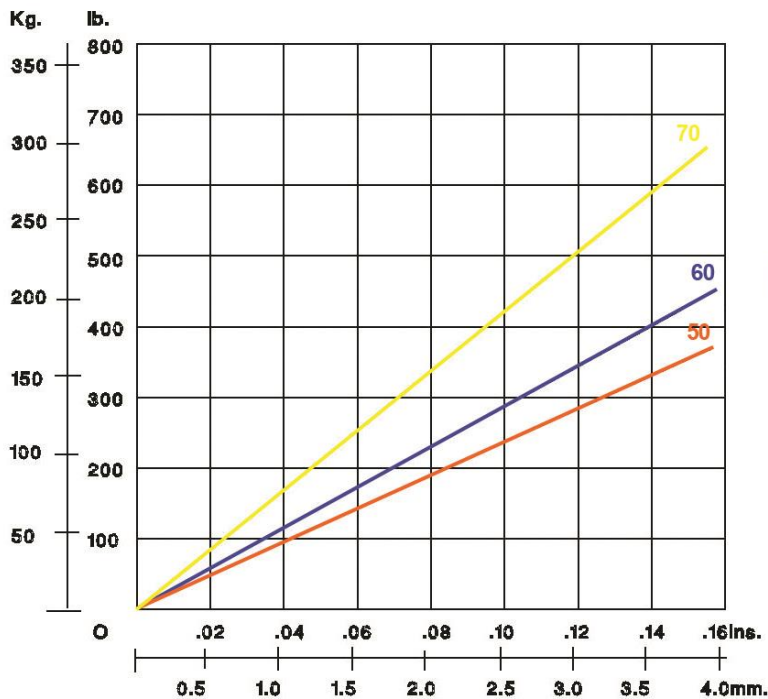

GRAPH : STATIC LOAD VS. DEFLECTION

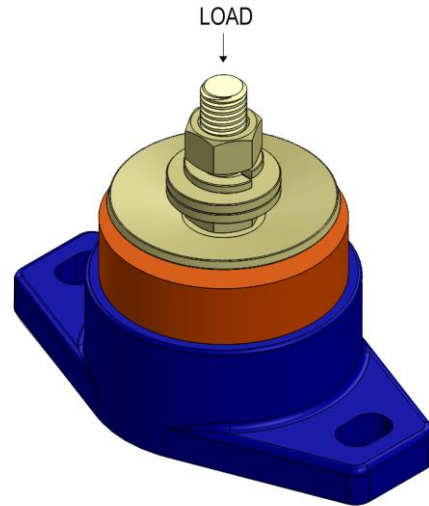

**Poly Flex** © 2015  
PRODUCTS

DRAWING No. P#4F64-17  
DRAWN OK. 01.06.15