

POLY FLEX DATA SHEET

PRODUCT: MOUNT **P-SYSTEM**®

MODEL: **P#4.9CTF60-15-12**

IDENTIFICATION SYSTEM				
P# <u> </u> F <u> </u> <u> </u> - <u> </u> - <u> </u> (<u> </u>)				
BASE TYPE	CORE DIA.	CORE HEIGHT	THREAD SIZE	CORE HARDNESS

CORE COLOUR	SHORE HARDNESS
ORANGE	50
BLUE	60
YELLOW	70

MATERIAL SPECIFICATION
 * ENGINEERING GRADE HEAT CURED POLYMER ALLOY
 * ALL METAL PARTS - GOLD PASSIVATED ZINC PLATED

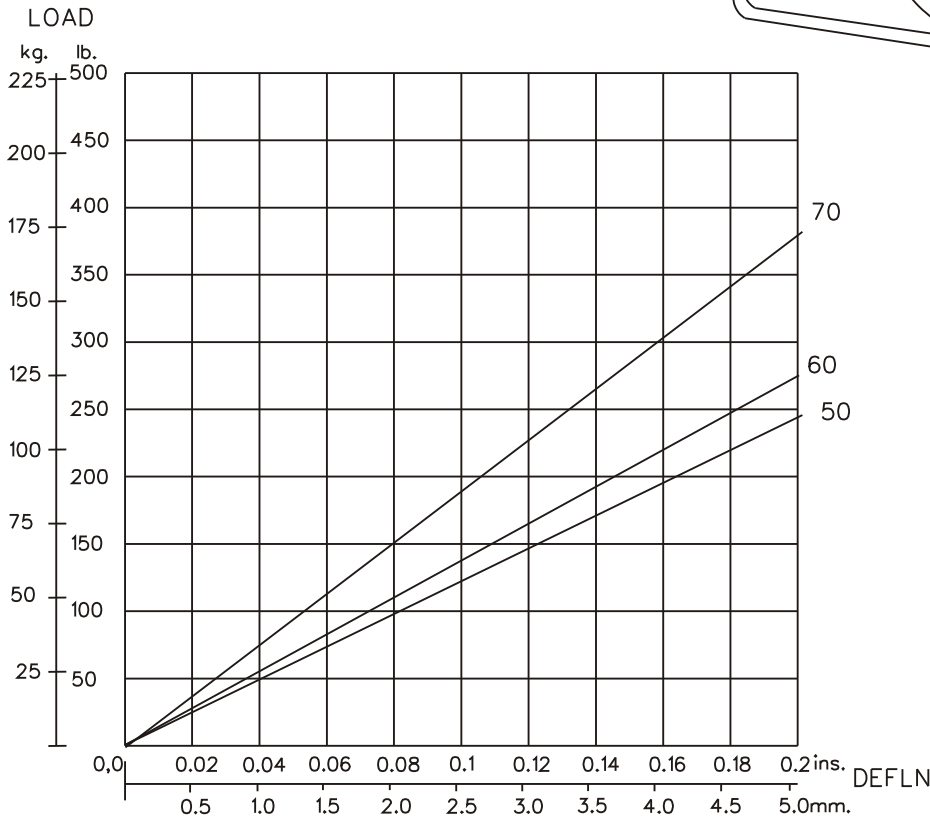
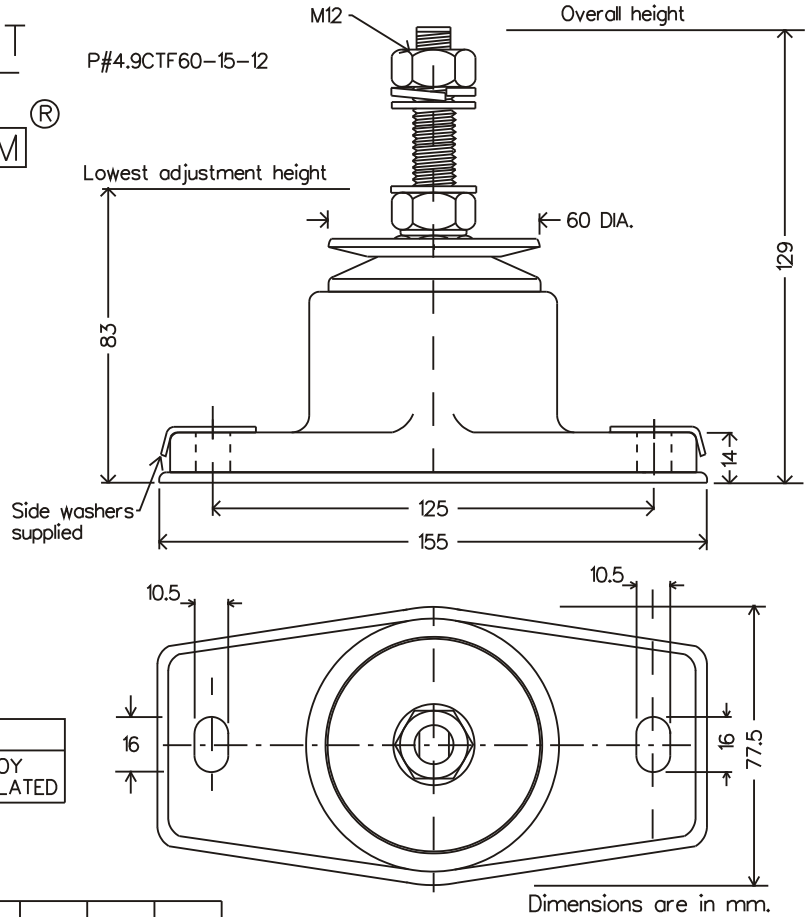

GRAPH 1 : STATIC AXIAL(VERTICAL) LOAD VS. DEFLECTION

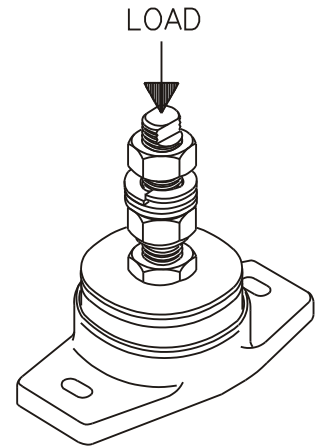

Poly Flex © 2003
Products

DRAWING NO: D4-9CF12
DRAWN PB.30/10/03