

POLY FLEX DATA SHEET

PRODUCT: MOUNT **P-SYSTEM**®

MODEL: **P#4.8CTF60-15-16L**

IDENTIFICATION SYSTEM				
P#FXX-XX-XX (XX)				
BASE TYPE	CORE DIA.	CORE HEIGHT	THREAD SIZE	CORE HARDNESS

CORE COLOUR	SHORE HARDNESS
ORANGE	50
BLUE	60
YELLOW	70

MATERIAL SPECIFICATION	
• ENGINEERING GRADE HEAT CURED POLYMER ALLOY	
• ALL METAL PARTS - GOLD PASSIVATED ZINC PLATED	

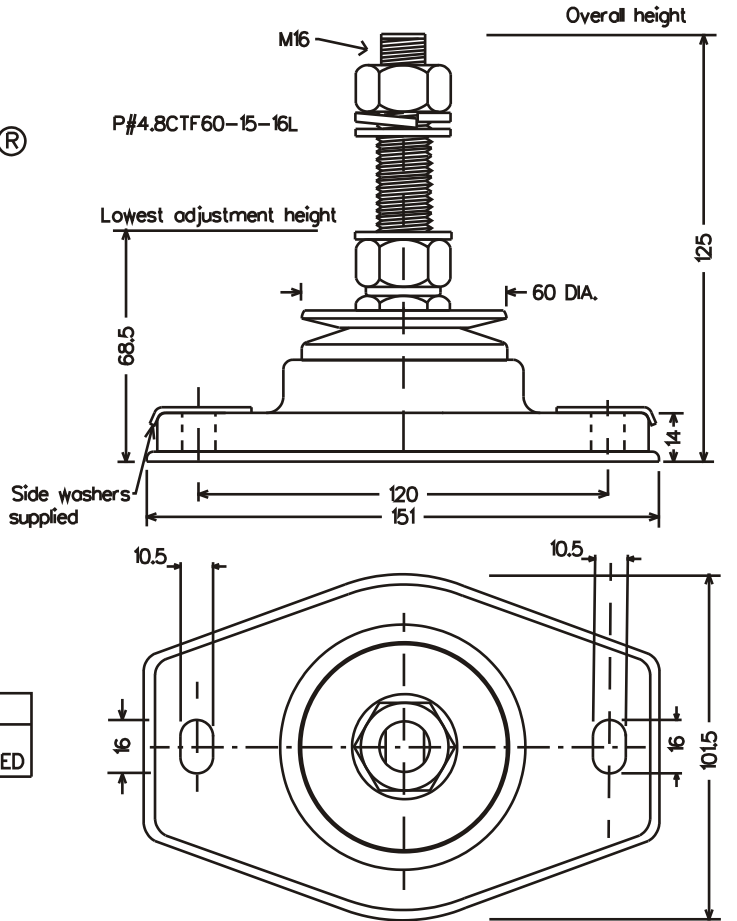

Dimensions are in mm.

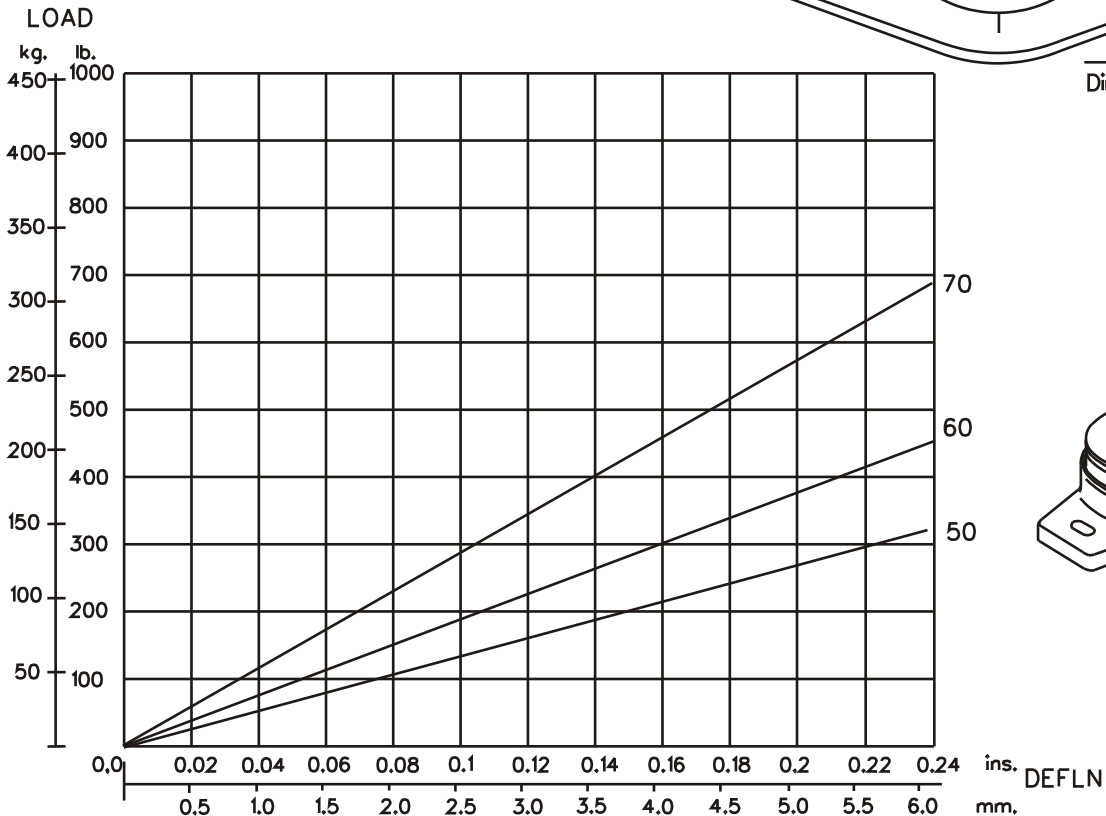

GRAPH 1 : STATIC AXIAL(VERTICAL) LOAD VS. DEFLECTION

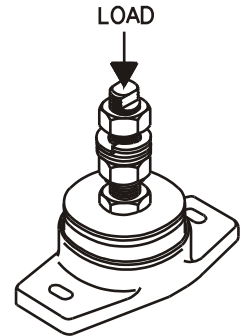

Poly Flex © 2002
Products

DRAWING NO: D4-8CT16L
DRAWN PB: 8/7/02