

POLY FLEX DATA SHEET

PRODUCT: MOUNT **P-SYSTEM**®

MODEL: **P#4.8F60-11-12**

IDENTIFICATION SYSTEM				
P#FXX-XX-XX (XX)				
BASE TYPE	CORE DIA.	CORE HEIGHT	THREAD SIZE	CORE HARDNESS

CORE COLOUR	SHORE HARDNESS
ORANGE	50
BLUE	60
YELLOW	70

MATERIAL SPECIFICATION	
* ENGINEERING GRADE HEAT CURED POLYMER ALLOY	
* ALL METAL PARTS - GOLD PASSIVATED ZINC PLATED	

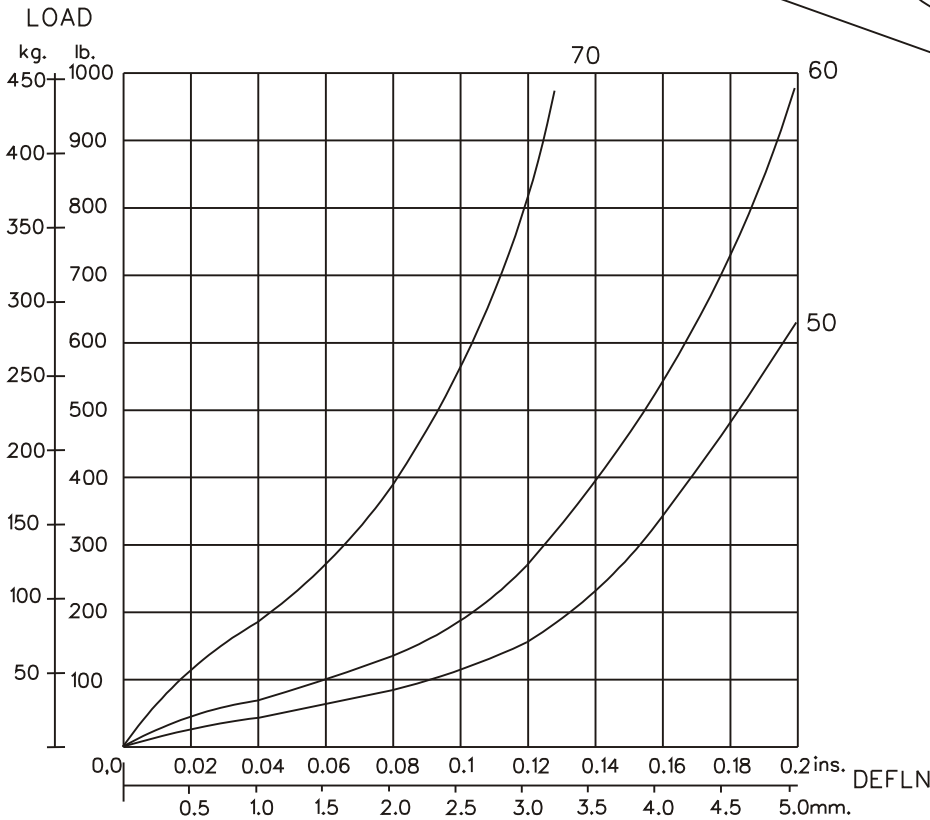
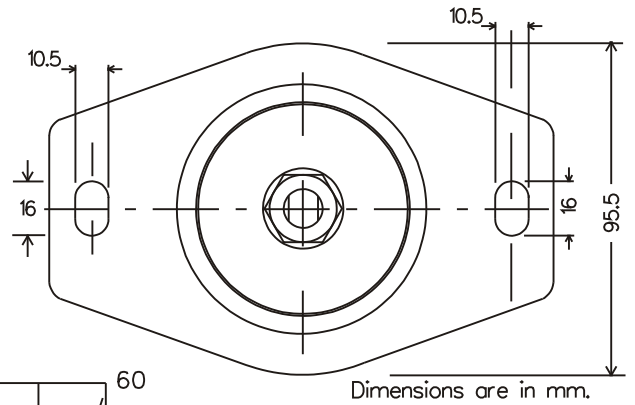
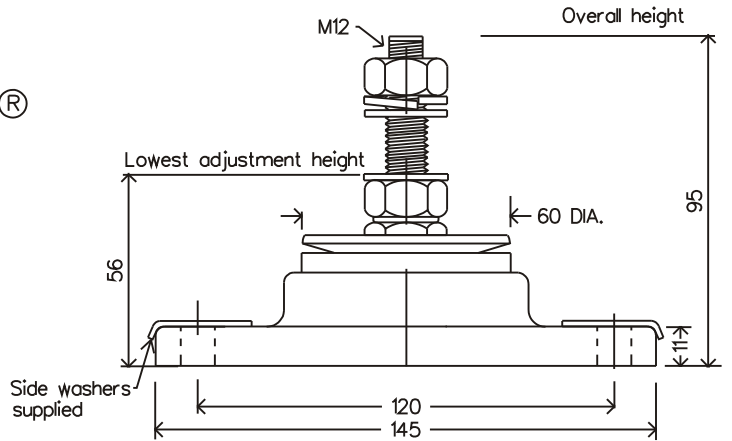

GRAPH 1 : STATIC AXIAL(VERTICAL) LOAD VS. DEFLECTION

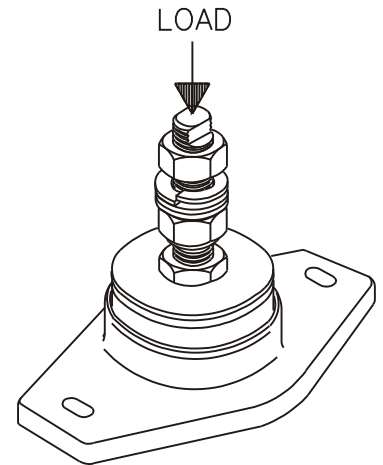

SUGGESTED CORE HARDNESS FOR: LIGHT DUTY HEAVY DUTY

THE ABOVE DATA IS SUPPLIED AS A GUIDE ONLY
PRODUCT SPECIFICATIONS AND DATA SHEETS ARE SUBJECT TO CHANGE WITHOUT NOTICE.

Poly Flex © 1999
Products

DRAWING NO: 4-860M12
DRAWN PB. 5/10/99