

POLY FLEX DATA SHEET

PRODUCT: MOUNT **P-SYSTEM**®

MODEL: **P#4.6F62-11-16**

IDENTIFICATION SYSTEM				
P# <u>4</u> F <u>62</u> - <u>11</u> - <u>16</u>				
BASE TYPE	CORE DIA.	CORE HEIGHT	THREAD SIZE	CORE HARDNESS

CORE COLOUR	SHORE HARDNESS
ORANGE	50
BLUE	60
YELLOW	70

MATERIAL SPECIFICATION
* ENGINEERING GRADE HEAT CURED POLYMER ALLOY
* ALL METAL PARTS - GOLD PASSIVATED ZINC PLATED

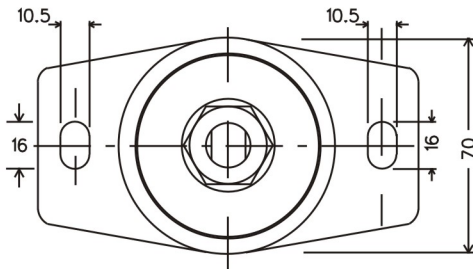
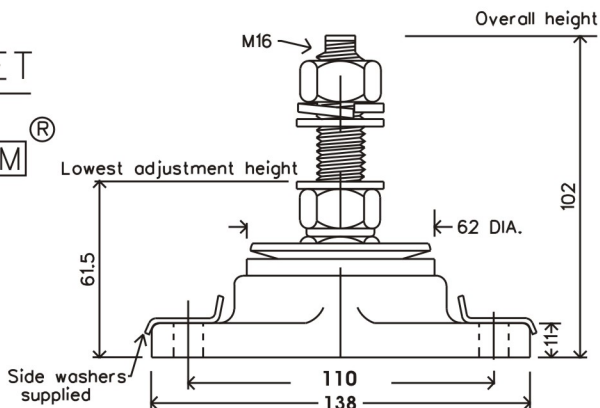

Dimensions are in mm.

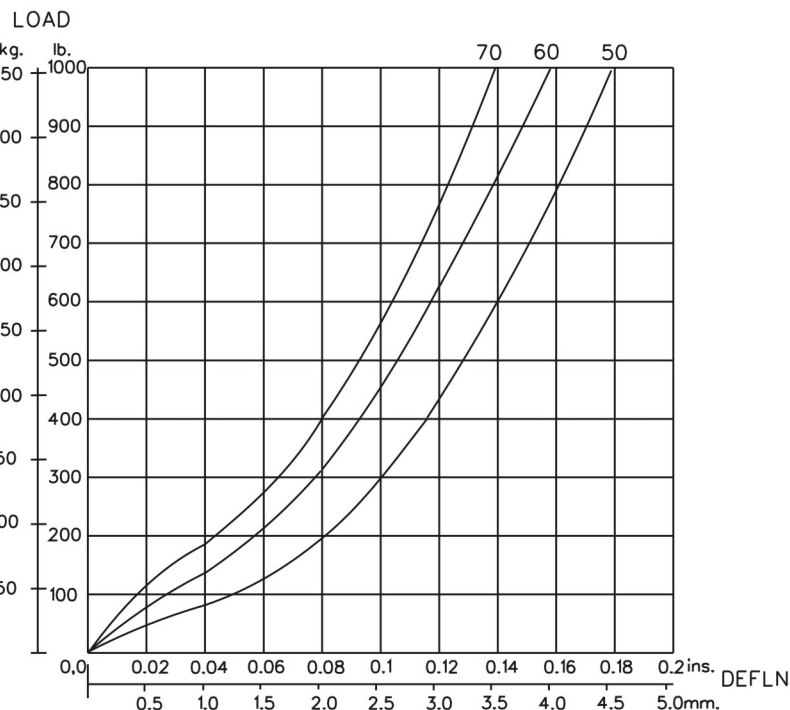
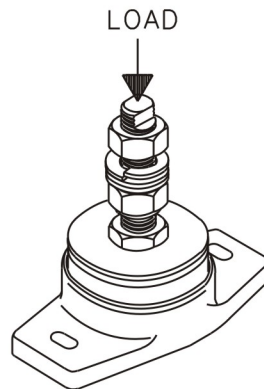

GRAPH 1 : STATIC AXIAL (VERTICAL) LOAD VS. DEFLECTION

SUGGESTED CORE HARDNESS FOR: LIGHT DUTY
HEAVY DUTY