

POLY FLEX DATA SHEET

PRODUCT: MOUNT P-SYSTEM[®]

SERIES: .5F SERIES

MODEL: P#4.5 F62-11-16 EXT ()

MATERIAL SPECIFICATION	
<ul style="list-style-type: none"> ENGINEERING GRADE HEAT CURED POLYMER ALLOY ALL METAL PARTS - SA5 COBALT ZINC PLATED 	

CORE COLOUR	SHORE HARDNESS
ORANGE	50
BLUE	60
YELLOW	70
GREEN	80

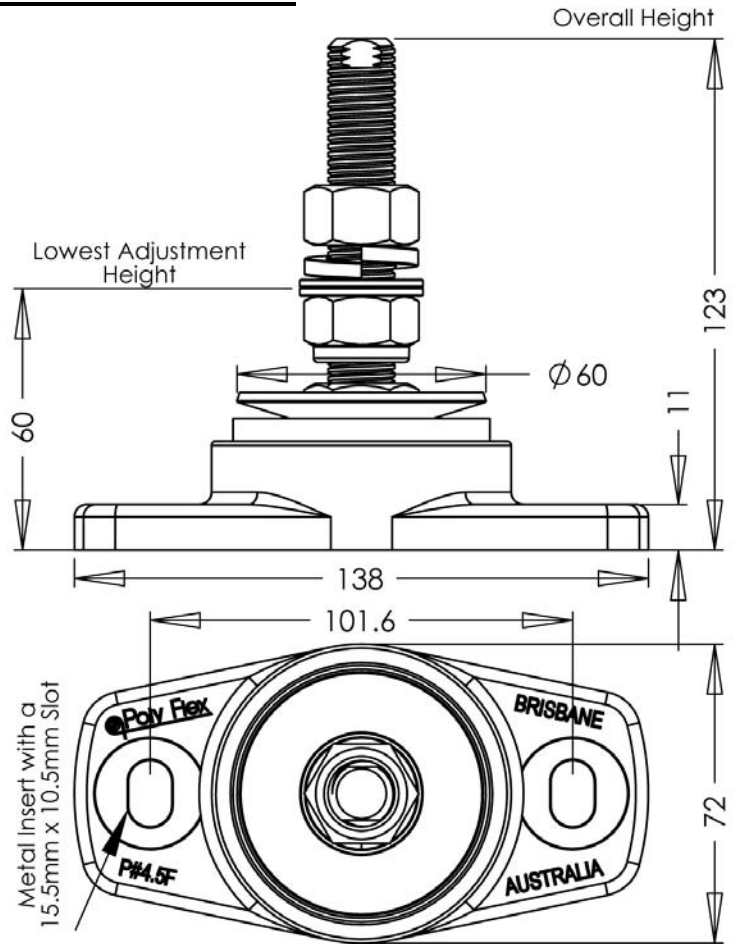

THE FOLLOWING DATA IS SUPPLIED AS A GUIDE ONLY. PRODUCT SPECIFICATIONS AND DATA SHEETS ARE SUBJECT TO CHANGE WITHOUT NOTICE.

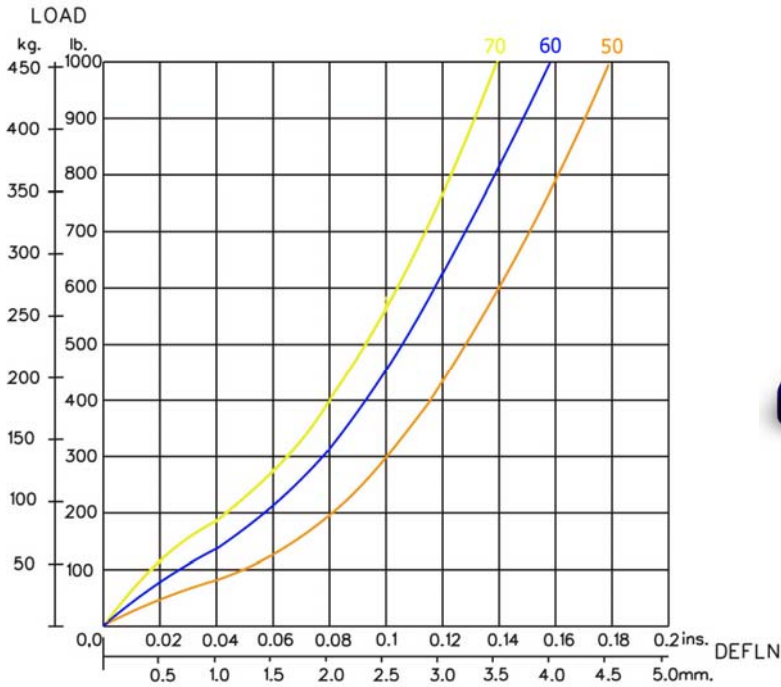

GRAPH 1 : STATIC AXIAL(VERTICAL) LOAD VS. DEFLECTION

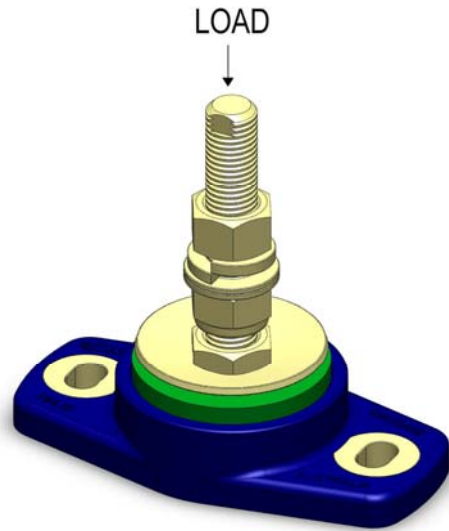

Poly Flex © 2009
PRODUCTS

DRAWING No. P#4.5F62-16X
DRAWN OK. 22.06.09