

POLY FLEX DATA SHEET

PRODUCT: MOUNT **P-SYSTEM**®
MODEL: **P#3.5F60-11-12**

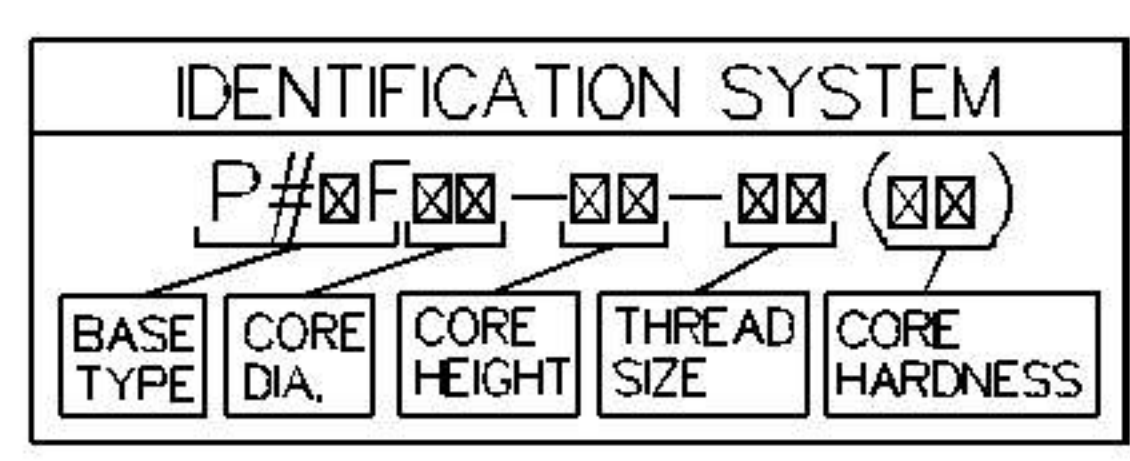

CORE COLOUR	SHORE HARDNESS
ORANGE	50
BLUE	60
YELLOW	70

MATERIAL SPECIFICATION

- * ENGINEERING GRADE HEAT CURED POLYMER ALLOY
- * ALL METAL PARTS - GOLD PASSIVATED ZINC PLATED

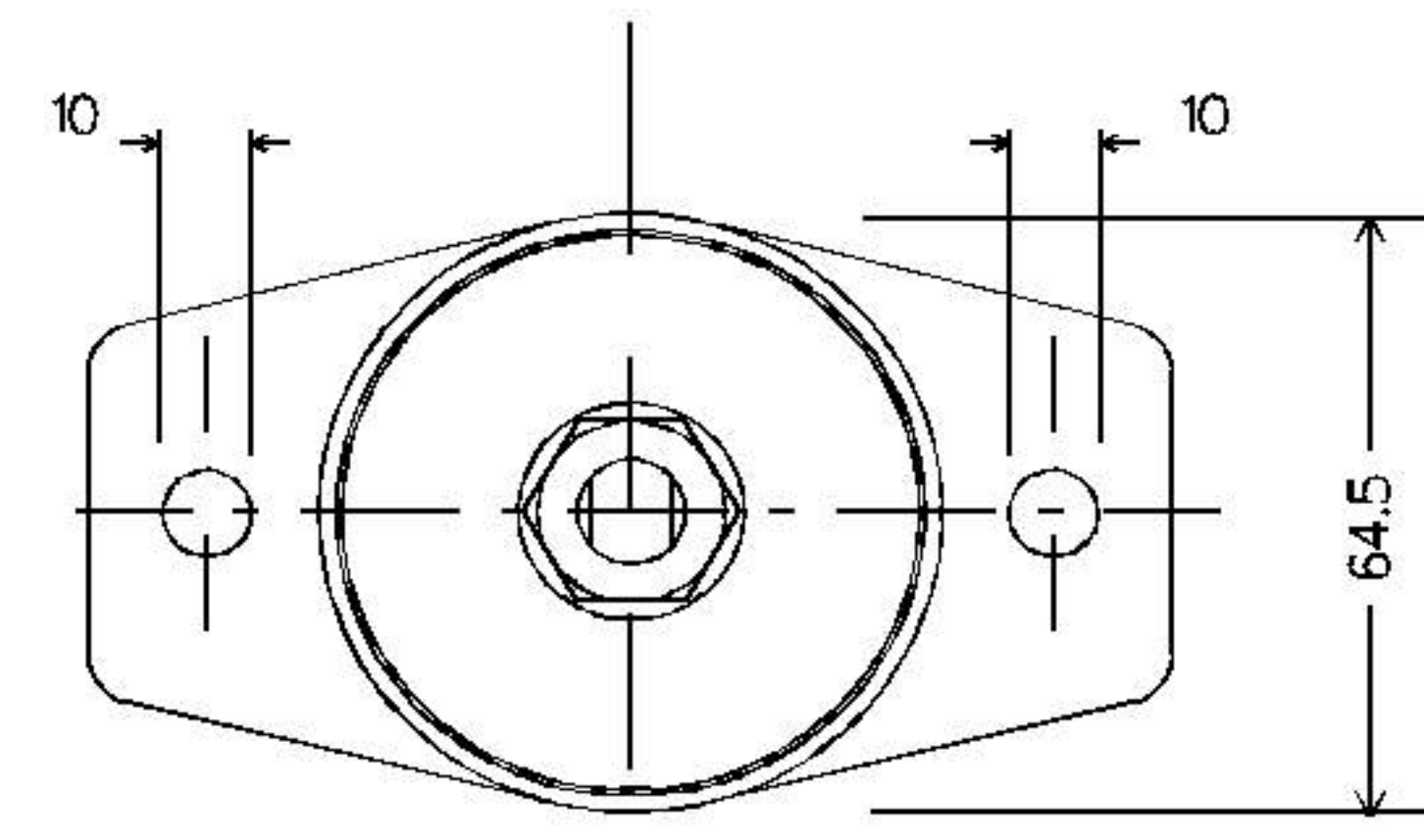
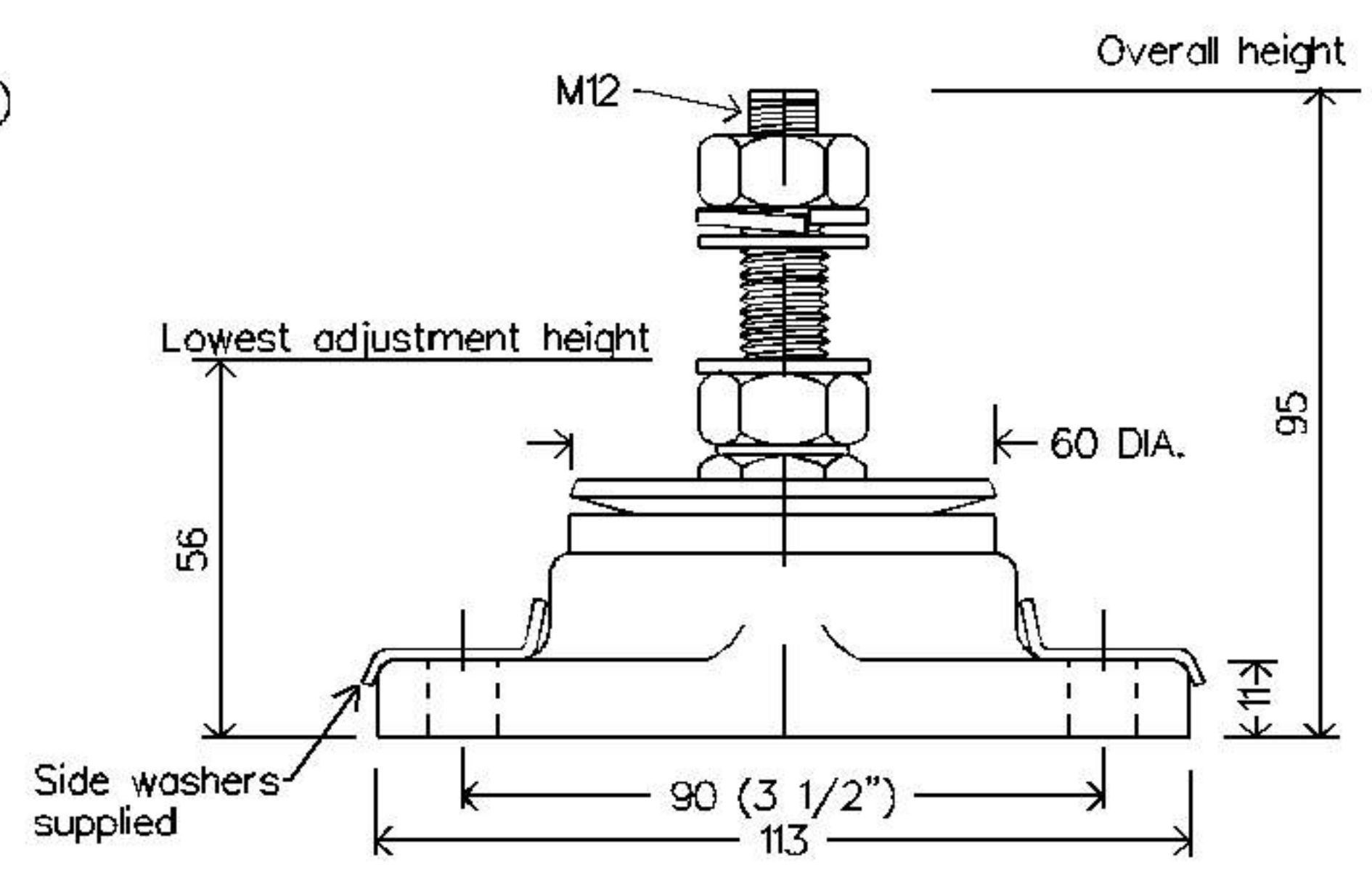

Dimensions are in mm.

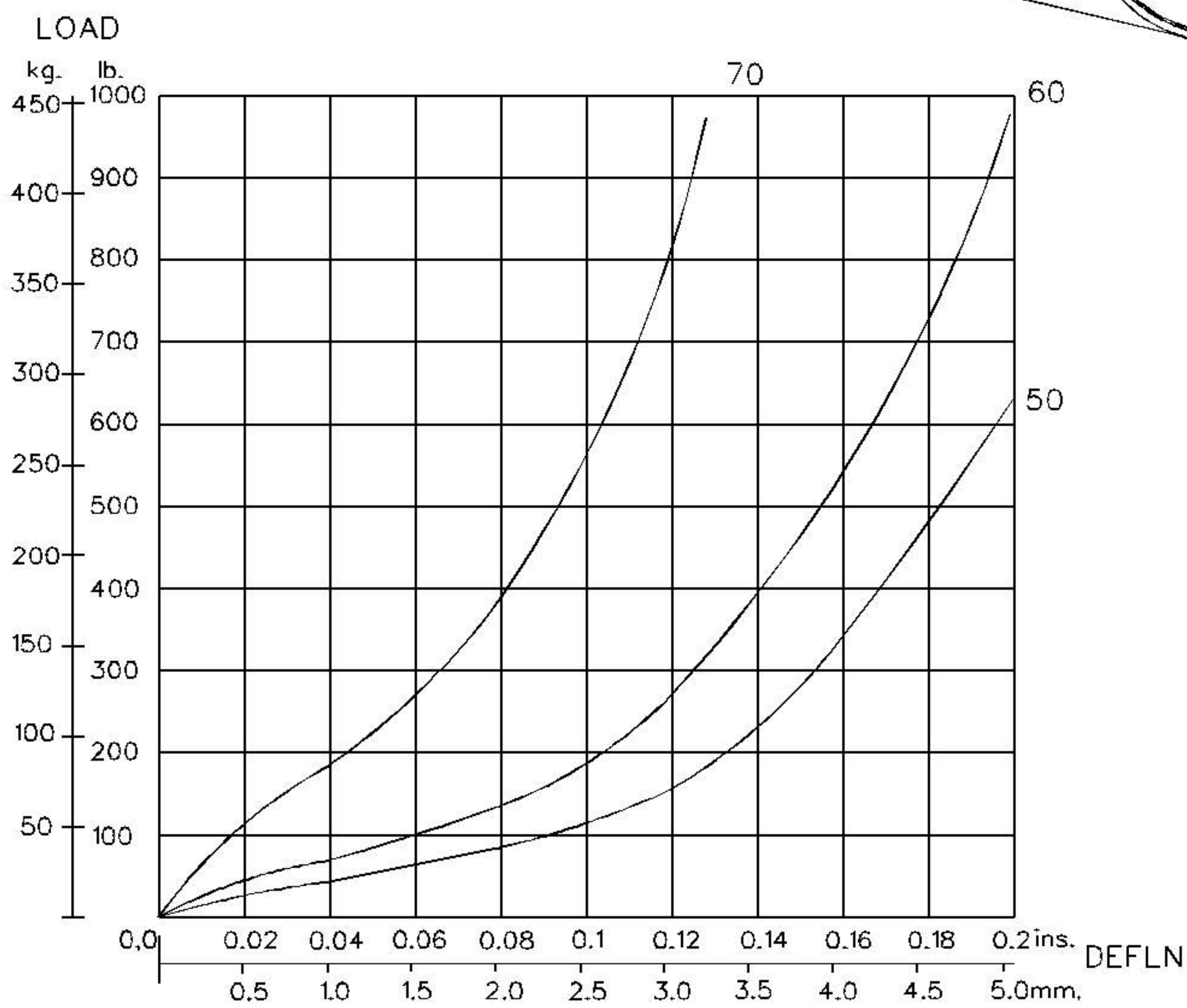

GRAPH 1 : STATIC AXIAL(VERTICAL) LOAD VS. DEFLECTION

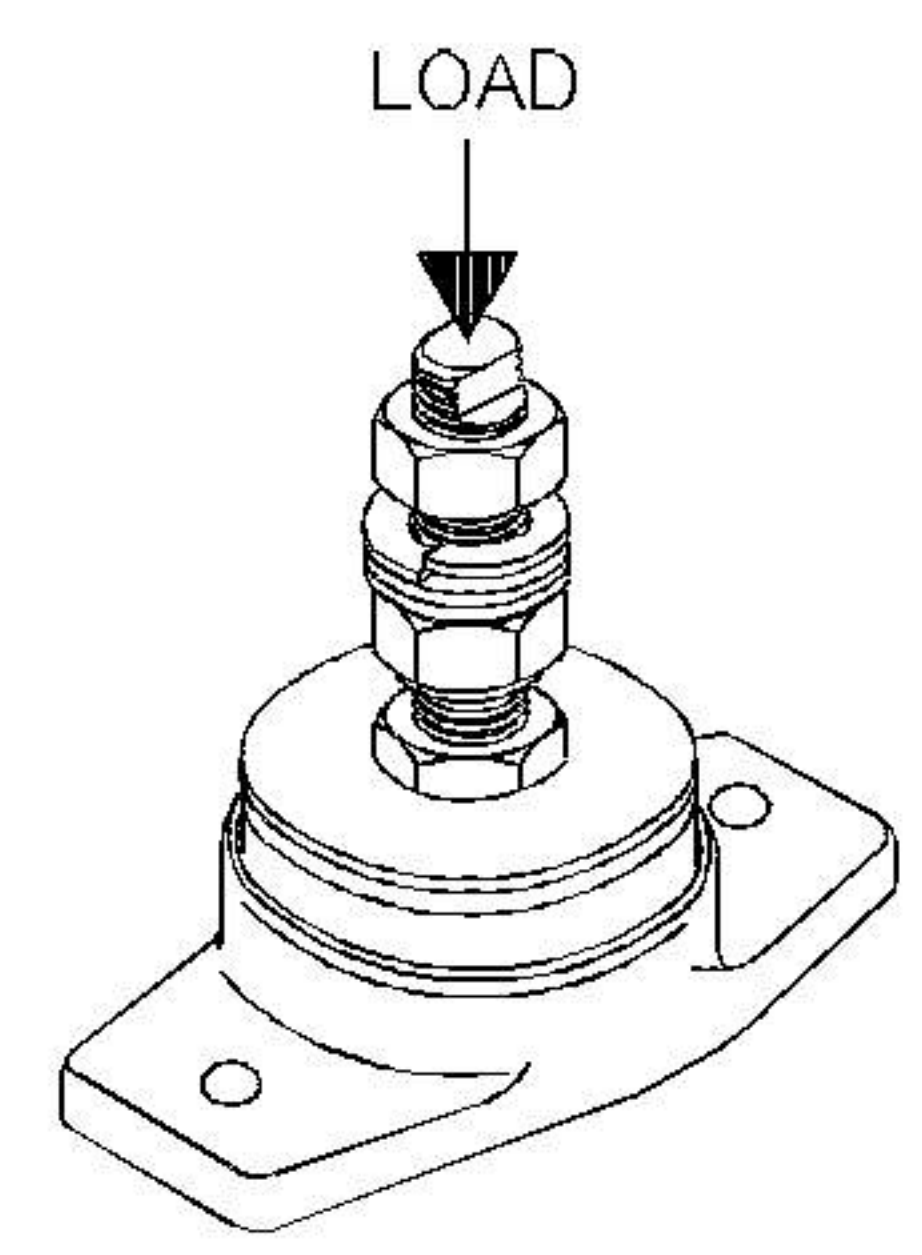

SUGGESTED CORE HARDNESS FOR: LIGHT DUTY
HEAVY DUTY

THE ABOVE DATA IS SUPPLIED AS A GUIDE ONLY
PRODUCT SPECIFICATIONS AND DATA SHEETS ARE SUBJECT TO CHANGE WITHOUT NOTICE.