

POLY FLEX DATA SHEET

PRODUCT: MOUNT **P-SYSTEM**®  
MODEL: **P#12.5CTF125-30-20A**  
with 2"AF hex Adjuster

IDENTIFICATION SYSTEM				
P#12.5CTF125-30-20A				
BASE TYPE	CORE DIA.	CORE HEIGHT	THREAD SIZE	CORE HARDNESS

CORE COLOUR	SHORE HARDNESS
ORANGE	50
BLUE	60
YELLOW	70
GREEN	80
RED	90

MATERIAL SPECIFICATION
• ENGINEERING GRADE HEAT CURED POLYMER ALLOY
• ALL METAL PARTS - GOLD PASSIVATED ZINC PLATED

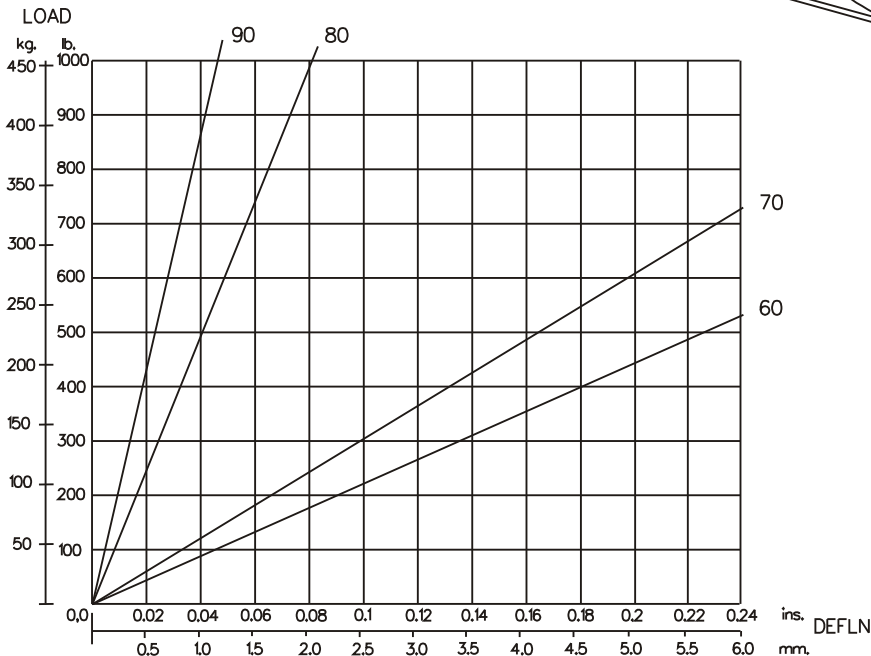
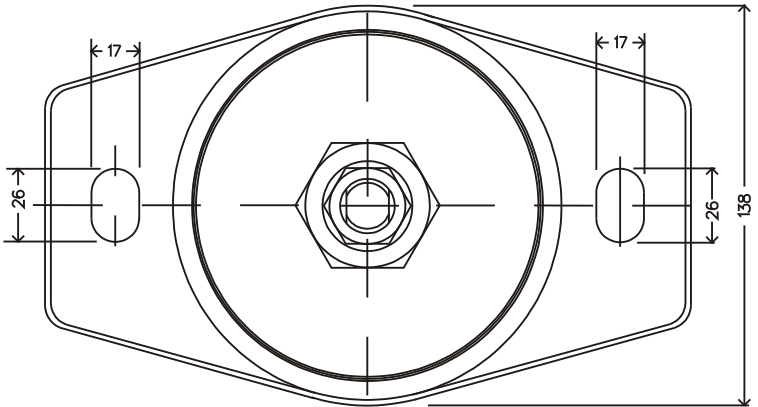
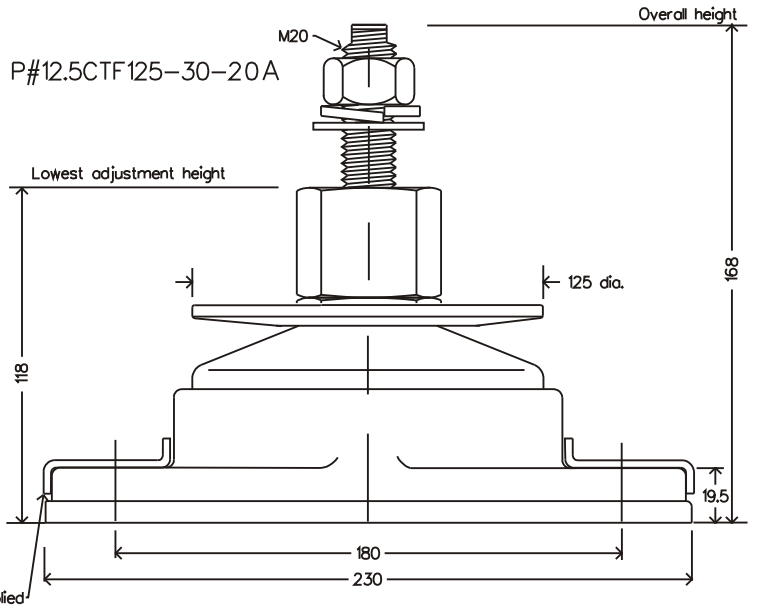

GRAPH 1 : STATIC AXIAL(VERTICAL) LOAD VS. DEFLECTION

THE ABOVE DATA IS SUPPLIED AS A GUIDE ONLY  
PRODUCT SPECIFICATIONS AND DATA SHEETS ARE SUBJECT TO CHANGE WITHOUT NOTICE.

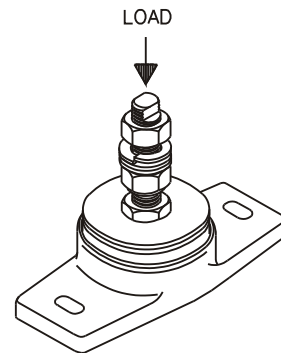

**Poly Flex** © 2003  
Products

DRAWING NO: D12-5C20A  
DRAWN PB. 26/5/03