

**POLY FLEX DATA SHEET**

PRODUCT: MOUNT P-SYSTEM<sup>®</sup>

SERIES: .5F SERIES<sup>®</sup>

MODEL: P#12.5F125-12-24 ( ) ADJ

MATERIAL SPECIFICATION	
• ENGINEERING GRADE HEAT CURED POLYMER ALLOY	
• ALL METAL PARTS – SA5 COBALT ZINC PLATED	

CORE COLOUR	SHORE HARDNESS
BLUE	60
YELLOW	70
GREEN	80
RED	90

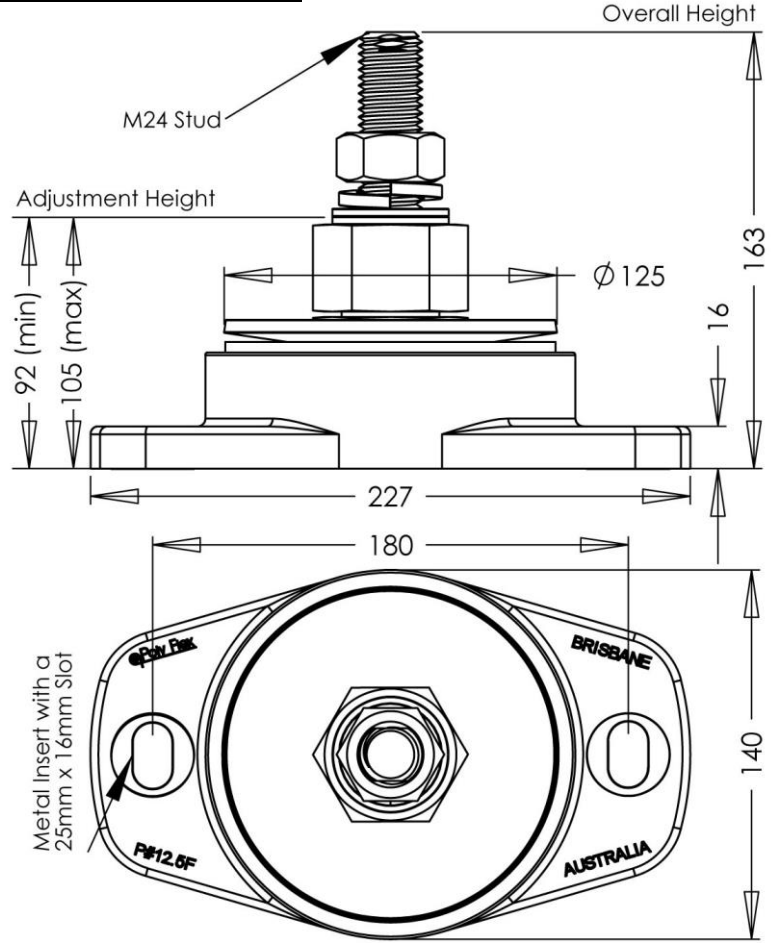

THE FOLLOWING DATA IS SUPPLIED AS A GUIDE ONLY. PRODUCT SPECIFICATIONS AND DATA SHEETS ARE SUBJECT TO CHANGE WITHOUT NOTICE.

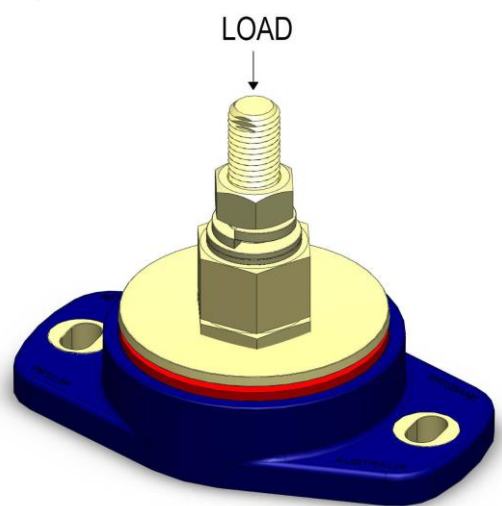
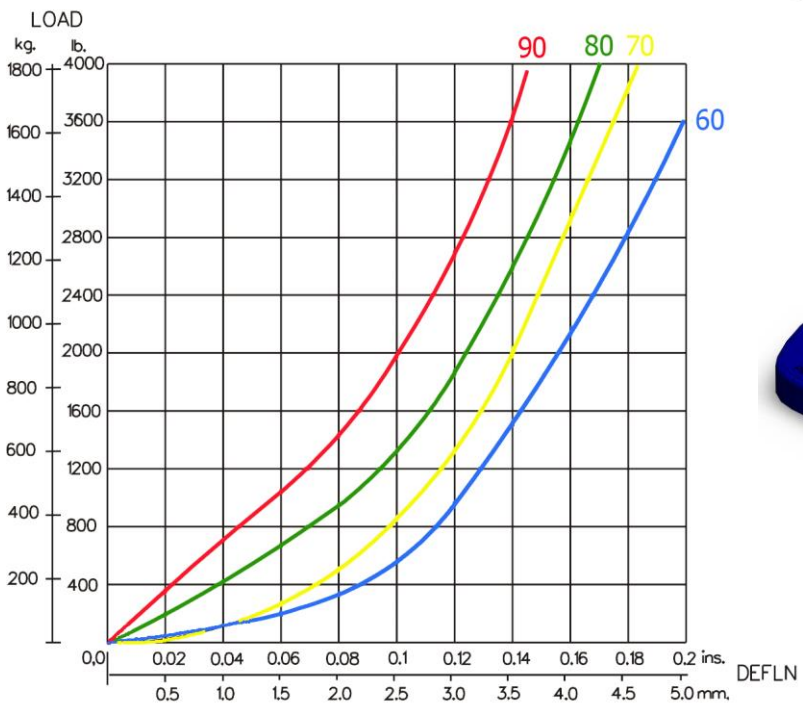

**Poly Flex** © 2009  
PRODUCTS  
DRAWING No. P#12.5F-24A  
DRAWN OK. 11.06.09

GRAPH 1 : TOTAL STATIC AXIAL(VERTICAL) LOAD VS. DEFLECTION