

- ① Coupling Disc - ENG Grade Polymer Alloy (Heat Cured) - 1 off
- ② 7/16UNF x 1 3/4 SHCS, Nut & S/W - Bolt Grade5 H/T - 4 off
- ③ 7/16UNF x 1 1/2 SHCS & S/W - Bolt Grade5 H/T - 4 off

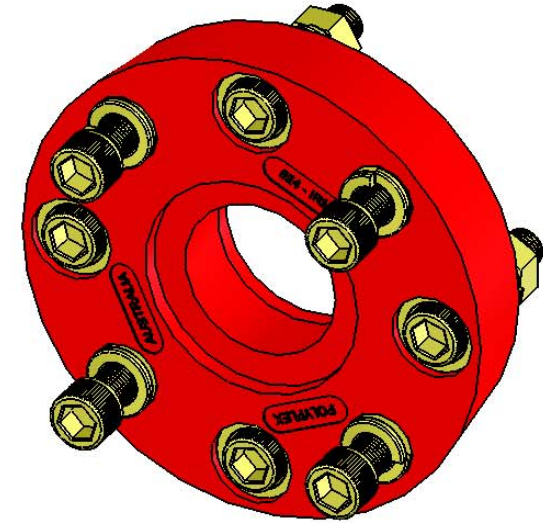

Male Spigot is 3mm Proud  
Female Spigot is 4mm Deep

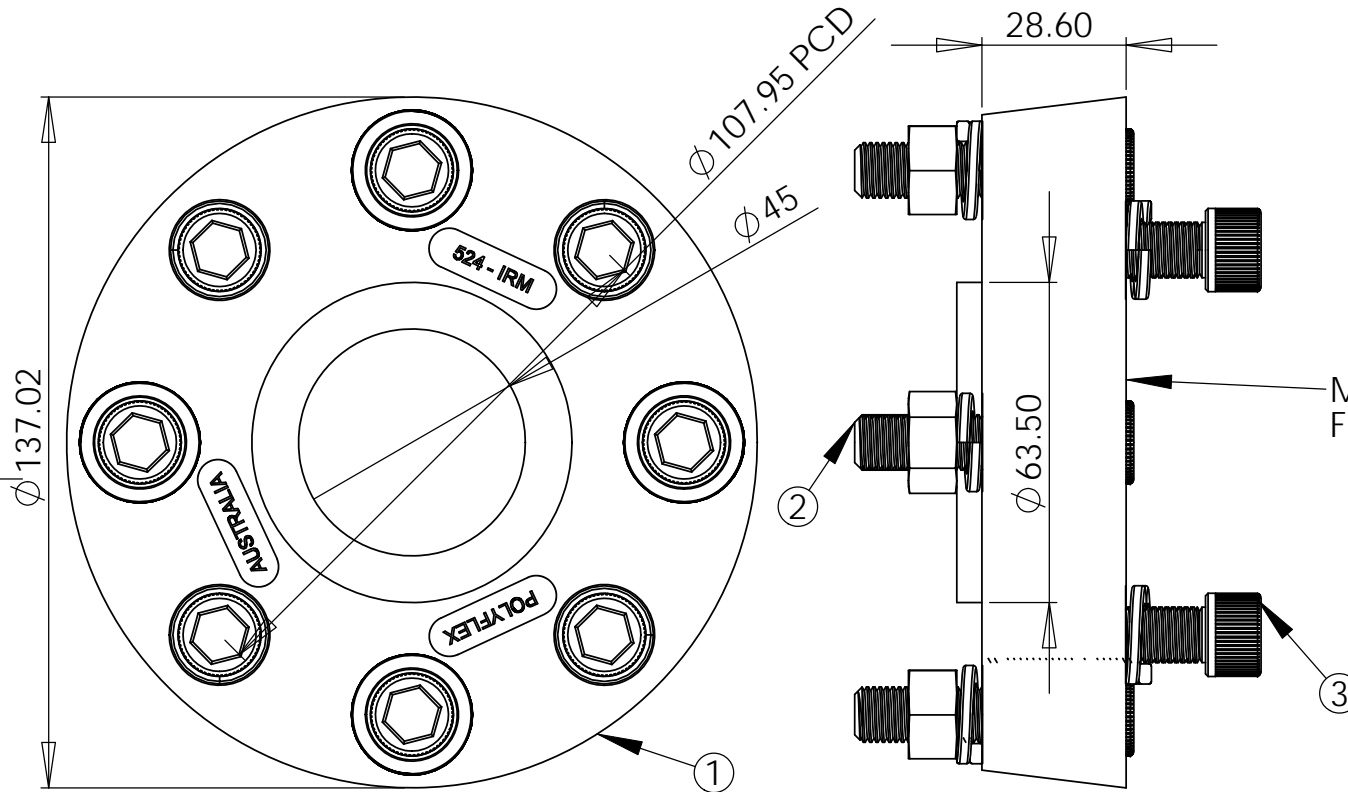

UNLESS OTHERWISE SPECIFIED:  
DIMENSIONS ARE IN MILLIMETERS  
SURFACE FINISH:  
TOLERANCES:  
LINEAR:  $\pm 0.25$   
ANGULAR:  $\pm 0.25$

DO NOT SCALE DRAWING

REVISION A

COMMENTS:

TITLE:

524-4-90 IRM Flexible  
Coupling 90 Red Duro

DWG NO.

524-4-90 IRM Flexible Coupling

A4

**PROPRIETARY & CONFIDENTIAL**  
THE INFORMATION CONTAINED IN THIS DRAWING IS THE SOLE PROPERTY OF  
POLY FLEX GROUP PTY LTD. ANY REPRODUCTION IN PART OR AS A WHOLE  
WITHOUT THE WRITTEN PERMISSION OF POLY FLEX GROUP PTY LTD IS PROHIBITED.

	NAME	SIGNATURE	DATE
DRAWN	OK		20.08.08
CHK'D	OK		20.08.08
APPV'D			
MFG	OK		-----
Q.A			

MATERIAL:  
90 Duro Urethane

WEIGHT:

SCALE:1:1

SHEET 1 OF 1