

# Poly Flex Data Sheet

**Product:** Steel Half Coupling

**Series:** Parallel Clamp

**Model:** 494 Parallel Clamp Half Coupling

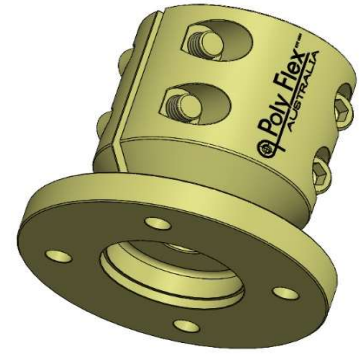

<u>Material Specification</u>	
· CNC Lathe - CS1020 Steel	
· All Metal Parts - SA5 Cobalt Zinc Plated	

<u>Weight Of Coupling</u>	
Kg	lbs
2.3	5.07

<u>Available Shaft Sizes</u>	
Metric	Inches
16mm to 38mm	5/8" to 1 1/2"

<u>Available Keyways</u>	
Metric	Inches
5mm - 3mm Deep	3/16" - 7/64" Deep
6mm - 3.5mm Deep	1/4" - 7/64" Deep
8mm - 4mm Deep	5/16" - 11/64" Deep
10mm - 4mm Deep	3/8" - 3/16" Deep
12mm - 4mm Deep	7/16" - 3/16" Deep
14mm - 5mm Deep	1/2" - 3/16" Deep
16mm - 5mm Deep	9/16" - 13/64" Deep
18mm - 5.5mm Deep	5/8" - 13/64" Deep
	3/4" - 7/32" Deep

<u>Available Grub Screws</u>	
8mm	10mm

<u>Transmission Cross Reference</u>	
Bukh / 4" Flange	
4 BOLT	

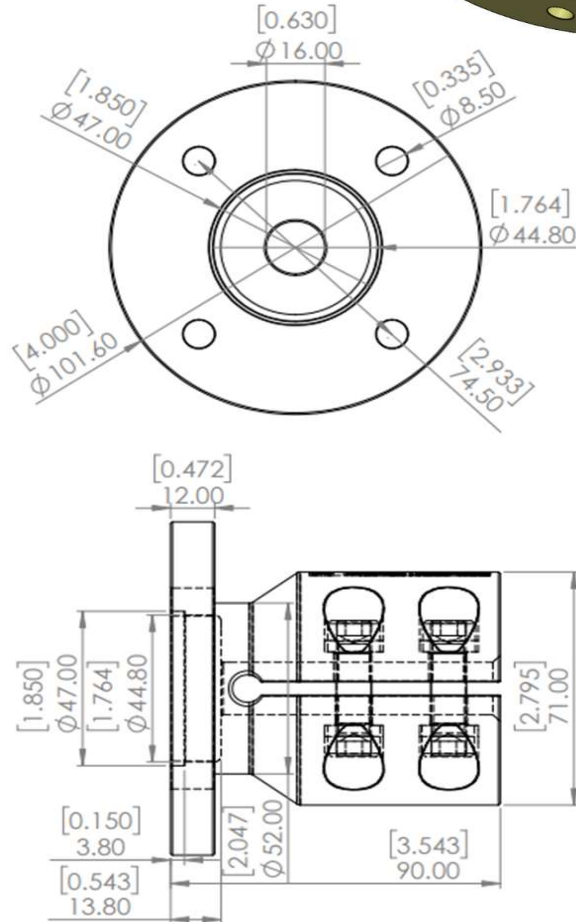

<u>Bolt Torque Settings</u>	
lb-ft	N-m
70	95

The following data is supplied as a guide only.  
Specifications are subject to change without notice.

Date: 13/06/2023

Copyright © 2022 Poly Flex Group Pty Ltd.



26 - 28 Tubbs Street Clontarf, Qld. 4019. Australia  
07 3284 2799 : Int Code +61  
info@polyflex.com.au  
www.polyflex.com.au



MARINE . MINING . DEFENCE . INDUSTRIAL . COMMERCIAL . AGRICULTURAL . AUTOMOTIVE  
Australian Made Quality & Performance that is Second to None